



NORDEN MFG

Owner's Manual

AF10 Hay Accumulator



MADE IN THE USA 

Read and understand the manual. This manual provides information and procedures to safely operate and maintain the Hay Accumulator.



CONTENTS

1. INTRODUCTION	4	7. OPERATION	27
1.1 Intended Usage	4	7.1 Operating Safety	27
1.2 Operator Orientation	4	7.2 Pre-Operation Checklist	27
1.3 Specifications	4	7.3 Attaching to Baler	27
1.4 Serial Number Location	4	7.3.1 Break In	28
1.5 Owner/Operator Manual Storage	5	7.3.2 Stuck Bale Removal	28
1.6 Product Improvements	5	7.4 Operating Procedures	28
1.7 Disposal of Equipment at End of Useful Life	5	7.4.1 Cornering	28
1.8 Unanswered Questions	5	7.4.2 Hillsides	28
		7.4.3 High Moisture Hay	28
		7.5 Detaching From Baler	28
2. SAFETY	6	8. TROUBLESHOOTING	29
2.1 General	6	8.1 Front Gate Bounces in Home Position	29
2.2 Safety Alert Symbol	6	8.2 Front Gate Bounces in Open Position	29
2.3 Safety Icons Nomenclature	7	8.3 Back Gate Trip Adjustments	30
2.3.1 Personal Protection/Important Information	7	8.4 Swing Arms	31
2.3.2 Prohibited Actions	7	9. TRANSPORTING	32
2.3.3 Hazard Avoidance	7	9.1 General Safety	32
2.4 General Operating Safety	8	9.2 Safety Chain	32
2.5 Safety Signs	8	9.3 Highway and Transport Operations	32
2.6 Practice Safe Maintenance	8	9.3.1 Setting the Hitch for Transport	33
2.7 Training	8	9.3.2 Lights	33
2.8 Sign-Off Form	9	9.4 Pre-towing Checklist	34
2.9 Operation Safety	10	10. STORAGE	35
2.10 Transporting Safety	10	10.1 Placing In Storage	35
2.11 Storage Safety	10	10.2 Removing From Storage	35
2.12 Maintenance Safety	10	11. MAINTENANCE	36
3. SAFETY SIGNS AND LABELS	11	11.1 Maintenance Safety	36
3.1 General Information	11	11.2 Lubrication	37
3.2 Contact Information	11	11.3 Wheel Bearing Adjustment	38
3.3 How to Install Replacement Safety Signs	11	11.4 Swivel Dolly Bushings	39
3.4 Safety Sign Locations	12	11.5 Tire Safety	39
3.5 Hay Accumulator Safety Signs	13	11.6 Tire Inflation	39
4. NAMES OF MAJOR PARTS	14	11.7 Bolt Torque Requirements	39
4.1 Undercarriage	15	11.8 Standard Torque Values	39
4.2 Accumulator Bed	15	11.9 Welding Repairs	39
4.3 Linkage System	15	11.10 Service Record	40
4.4 Belted Base Chute	15	12. PARTS SECTION	41
4.5 Lights	15	12.1 Ordering Parts	41
4.6 Linkage System Operation	16	12.2 Contact Information	41
5. ASSEMBLY	18	12.3 Decals	41
6. SET-UP	21	12.4 Hay Accumulator Undercarriage	42
6.1 User Safety Training	21	12.5 Hub Assembly	43
6.2 Tractor Requirements	22	12.6 Accumulator Bed and Chute	44
6.2.1 Equipment and Capabilities	22	12.7 Linkage System	45
6.2.2 Tractor Safety Devices	22	12.8 Belt and Tensioner	46
6.3 Baler Hitch Setup	22	12.9 Bale Chamber Extension	47
6.4 Baler Chamber Settings	25	12.10 Lighting	48
6.5 Baler Hitch Special Requirements	25		
6.5.1 Older New Holland® (NH) Balers	25		
6.5.2 Newer New Holland® Balers	26		
6.5.3 John Deere® (JD) Balers (1988 and newer)	26		
6.5.4 Inline Balers	26		
6.6 Lighting Socket Holder	26		

1. Introduction

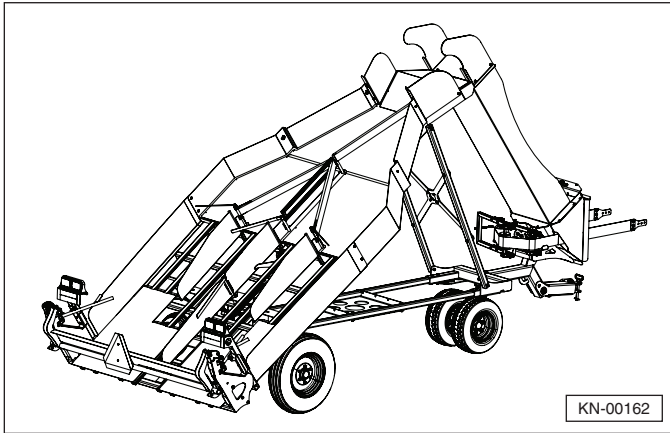

Using no hydraulics or electronics, the Norden Hay Accumulator automatically arranges bales into groups that can then be picked up with a Grabber mounted on a loader. Handling multiple bales of hay at one time allows wagons to be loaded more quickly, as well as quicker stacking in the barn.

Please read the manual carefully to become familiar with your new Norden Hay Accumulator. This manual has been developed through our experience with the equipment and feedback from our customers. Ultimately it is our desire that you will be operating your Hay Accumulator as a seasoned professional in no time!

1.1 Intended Usage

Do not use this Hay Accumulator for any other purpose than its intended use of arranging bales into groups that can then be picked up with Grabbers.

1.2 Operator Orientation

The directions left, right, front, and rear, as mentioned throughout this manual, are as seen from the tractor operator's seat and facing in the direction of travel.

1.3 Specifications

Overall Width	7' 10"
Overall Length	18' 10"
Overall Height	10' 1"
Overall Weight	2205 lbs.
Bale Capacity	10
Bale Size	14 x 18", 32 to 38" long
Tires	ST 225/75R15 (Rear) 20.5 x 8-10 (Front)

Specifications subject to change without notice.

1.4 Serial Number Location

The Hay Accumulator's serial number is located near the front of the Hay Accumulator Bed. Please use this number when requesting service, seeking information, or ordering parts. Record the serial number in the space provided for easy reference when contacting Norden Mfg LLC with questions.

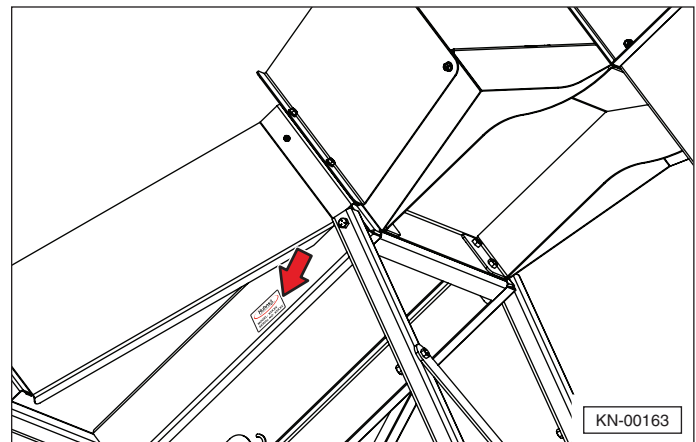

Serial Number _____

Date of Purchase _____

1.5 Owner/Operator Manual Storage

Store the Owner/Operator manual and other operating materials in the document storage tube, located under the accumulator bed.

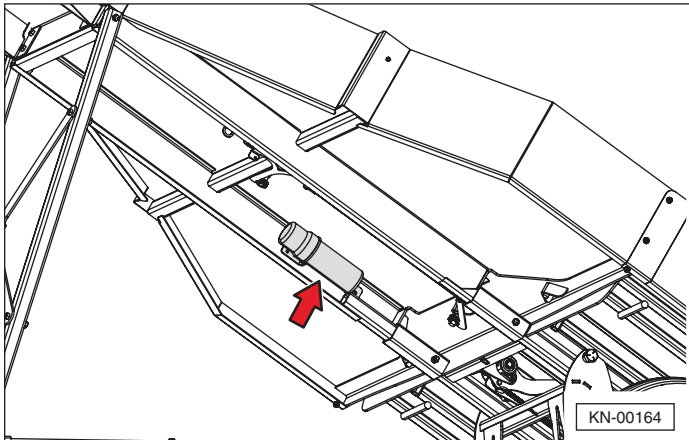

1.6 Product Improvements

Because Norden Mfg LLC maintains an ongoing program of product improvement, we reserve the right to make improvements in design or changes in specifications without incurring any obligation to install them on units previously sold.

1.7 Disposal of Equipment at End of Useful Life

The Norden Mfg LLC Hay Accumulator has been designed for the specific purpose of arranging bales into groups. When this unit is no longer capable of performing its intended use, it should be dismantled and scrapped. Do not use any materials or components from this unit for any other purpose.

1.8 Unanswered Questions

If you have any questions not answered in this manual, require additional copies, or the manual is damaged, please contact your dealer, or:

Norden Mfg LLC
4210 Kinsman Road NW
North Bloomfield, OH 44450

Phone: 877-296-5851
Fax: 440-693-4336
E-mail: parts@Nordenmfg.com

The manual is also available for download at:
www.Nordenmfg.com

2. Safety

2.1 General

Most work related accidents are caused by failure to observe basic safety rules or precautions. An accident can often be avoided by recognizing potentially hazardous situations before an accident occurs. As you operate and maintain the Hay Accumulator, you must be alert to potential hazards. You should also have the necessary training, skills, and tools to perform any assembly procedure.

Improper operation and/or maintenance of this unit could cause a dangerous situation that results in injury or death.

Do not use this unit until you read and understand the information contained in this manual. Do not use the Hay Accumulator for anything other than its intended purpose.

WARNING



Do not use the unit until you read and understand the information contained in this manual and all related equipment manuals.



Safety precautions and warnings are provided in this manual and on the unit. If these hazard warnings are not heeded, bodily injury or death could occur to you or to other persons.

Norden Mfg LLC cannot anticipate every possible circumstance that might involve a potential hazard. The warnings in this manual and on the product are, therefore, not all-inclusive. If a method of operation not specifically recommended by us is used, you must satisfy yourself that it is safe for you and for others. You should also ensure that the unit will not be damaged or be made unsafe by the methods that you choose.

The information, specifications, and illustrations in this manual are based on the information that was available at the time this material was written and can change at any time.

2.2 Safety Alert Symbol



This is the safety alert symbol. It is used to alert you to potential personal injury hazards. Obey all safety messages that follow this symbol to avoid possible injury or death.

This manual contains WARNINGS, CAUTIONS, NOTICES, SAFETY INSTRUCTIONS, and NOTES which must be followed to prevent the possibility of improper service, damage to the equipment, personal injury, or death. The following key words call the reader's attention to potential hazards.

Hazards are identified by the "Safety Alert Symbol" and followed by a signal word such as "WARNING" or "CAUTION".

WARNING

Indicates a potentially hazardous situation which, if not avoided, could result in death or serious injury.

CAUTION

Indicates a potentially hazardous situation which, if not avoided, may result in minor or moderate injury.

NOTICE

Indicates that equipment or property damage can result if instructions are not followed.

SAFETY INSTRUCTIONS















Safety instructions (or equivalent) signs indicate specific safety-related instructions or procedures.

Note: Contains additional information important to a procedure.

2.3 Safety Icons Nomenclature

This manual and the equipment has numerous safety icons. These safety icons provide important operating instructions which alert you to potential personal injury hazards

2.3.1 Personal Protection/Important Information

-  Read the manual
-  Eye protection
-  Hearing protection
-  Hand protection
-  Foot protection
-  First aid kit
-  Fire extinguisher
-  Inspect equipment
-  Use proper tools
-  Use support stands
-  Weight rating
-  Use OEM parts
-  Use ROPS and seat belt
-  Maintain safety signs
-  Place in park
-  Remove key
-  Stop engine
-  Visibility
-  Set parking brake

2.3.2 Prohibited Actions

-  Do not alter or modify
-  Do not weld
-  No riders
-  No children
-  No alcohol
-  No drugs

2.3.3 Hazard Avoidance

-  Crushing hazard
-  Crushing hazard
-  Slipping hazard
-  Tripping hazard
-  Falling hazard
-  Fire hazard
-  Safety alert symbol
-  Maintain tire pressure
-  Defective or broken part
-  Chock wheels
-  Maintain safe distance
-  Pinch point hazard
-  Overturn hazard
-  Negative tongue weight hazard
-  Rollover hazard

2.4 General Operating Safety

WARNING



Read And Understand Manual

To prevent personal injury or even death, be sure you read and understand all of the instructions in this manual and other related OEM equipment manuals! This Hay Accumulator (unit) was designed for a specific application; DO NOT modify or use this unit for any application other than that for which it was designed. Units operated improperly or by untrained personnel can be dangerous! Inexperienced operators should receive instruction from someone familiar with the equipment before being allowed to operate the unit.



Do Not Operate

Do not use the unit if it is in need of repair. If you believe the unit has a defect which could cause injury or death, you should immediately stop using the unit.



Fall Hazard

Do not use the unit as a platform. Do not climb on the unit. Do not stand on the unit at any time. Do not ride on the unit or allow others to ride on it.



Pinch Point Hazard

Keep hands and feet away from any moving parts to prevent them from getting pinched.



Impaired User Hazard

Do not attempt to assemble, operate, or maintain the Hay Accumulator under the influence of drugs or alcohol. Consult your doctor before using the Hay Accumulator while taking prescription medications.



Falling Hazard

Do not allow riders on the tractor or Hay Accumulator at any time. Falling can result in severe injuries or death.



Stay Clear

Clear the area of people, especially small children, before using the Hay Accumulator. Under no circumstances should young children be allowed to work with or around the Hay Accumulator.

2.5 Safety Signs

CAUTION



Legible Safety Signs

Keep safety signs clean and legible at all times. Replace any safety sign or instruction sign that is missing or not legible. Refer to the Safety Sign Location section for additional information.

When replacing parts that displayed a safety sign, replace the safety sign as well.

Replacement safety signs (labels) are available from your authorized Dealer Parts Department or the factory at no cost.

2.6 Practice Safe Maintenance

SAFETY INSTRUCTIONS



Understand service procedures before doing any work. Keep the work area clean and dry.



Keep all parts in good working condition and properly installed. Replace worn or broken parts immediately.



Do not modify the unit or its safety devices. Do not weld on the unit. Unauthorized modifications may impair its function and safety.

2.7 Training

Anyone who will be using and/or maintaining the Hay Accumulator must read, clearly understand, and follow ALL safety, operation, and maintenance information presented in this manual, other related OEM manuals, and the safety signs.

If you do not understand any information in this manual, see your dealer or contact Norden Mfg LLC before proceeding.

Do not use or allow anyone else to use this Hay Accumulator until all information has been reviewed. Annually review this manual before the season start-up.

Make periodic reviews of SAFETY and OPERATION a standard practice. An untrained operator is not qualified to use this Hay Accumulator.

2.8 Sign-Off Form

Norden Mfg LLC follows the general Safety Standards specified by the Farm Equipment Manufacturers Association (FEMA), and the American National Standards Institute (ANSI). Anyone who will be using and/or maintaining the Hay Accumulator must read and clearly understand ALL safety, operation and maintenance information presented in this manual.

Do not use or allow anyone else to use this equipment until all information has been reviewed. Annually review this manual before the season start-up.

Make periodic reviews of SAFETY and OPERATION of the Hay Accumulator a standard practice. An untrained operator is not qualified to use this Hay Accumulator.

This sign-off sheet is provided for your records to show that all personnel who will be working with the equipment have read and understand the information in this Operation and Parts Manual and have been instructed in the operation of the equipment.

Sign-Off Form		
Date	User's Signature	Owner's Signature

2.9 Operation Safety

Refer to “2.4 General Operating Safety” on page 8 for safety recommendations related to using the Hay Accumulator. All applicable safety recommendations in other sections should also be followed.

2.10 Transporting Safety

Refer to “9. Transporting” on page 32 for safety recommendations related to transporting the Hay Accumulator. All applicable safety recommendations in other sections should also be followed.

2.11 Storage Safety

Refer to “10. Storage” on page 35 for safety recommendations related to storing the Hay Accumulator. All applicable safety recommendations in other sections should also be followed.

2.12 Maintenance Safety

Refer to “11. Maintenance” on page 36 for safety recommendations related to maintaining the Hay Accumulator. All applicable safety recommendations in other sections should also be followed.

3. SAFETY SIGNS AND LABELS

3.1 General Information

The types of safety signs (hazard labels) and instructional labels, along with their locations on the equipment, are shown in the following illustrations. Good safety practices require that you familiarize yourself with the various safety signs, the type of warning, and the area or particular operation related to that area that requires your SAFETY AWARENESS.



Think SAFETY!

Work SAFELY!

Pay close attention to the safety signs and instructional labels attached to the tractor, baler, and Hay Accumulator. The safety signs attached to the Hay Accumulator are reproduced in this section. If the Hay Accumulator is missing a label or one is unreadable, replace the label before using the Hay Accumulator.

**SAFETY
INSTRUCTIONS**



Safety Signs and Instructional Labels

Keep safety signs or instructional labels clean and legible at all times. Use a clean, damp cloth to clean safety decals.

1. Replace any missing or hard-to-read safety signs or instructional labels.
2. Use care when washing or cleaning the equipment. Make sure not to remove or damage the labels. When using a pressure washer to clean the Hay Accumulator, avoid spraying too close to decals; high-pressure water can enter through very small scratches or under edges of decals causing them to peel or come off.
3. Locations for the labels and replacement part numbers are shown in this section.
4. Replacement parts must have replacement labels attached before the Hay Accumulator is used.
5. Labels are available from your authorized dealer or from Norden Mfg LLC at no charge.

3.2 Contact Information

For replacement decals, contact:

Norden Mfg
4210 Kinsman Road NW
North Bloomfield, OH 44450

Phone: 877-296-5851
Fax: 440-693-4336
E-mail: parts@Nordenmfg.com

3.3 How to Install Replacement Safety Signs

1. Clean and dry the installation area.

Note: Do not install the signs if the temperature is below 50°F.

2. Determine the exact position before you remove the backing paper.
3. Remove the backing paper.
4. Align the sign over the specified area and carefully press the sign to the part/frame.

Note: Small air pockets can be pierced with a pin and smoothed out using the piece of backing paper.

3.4 Safety Sign Locations

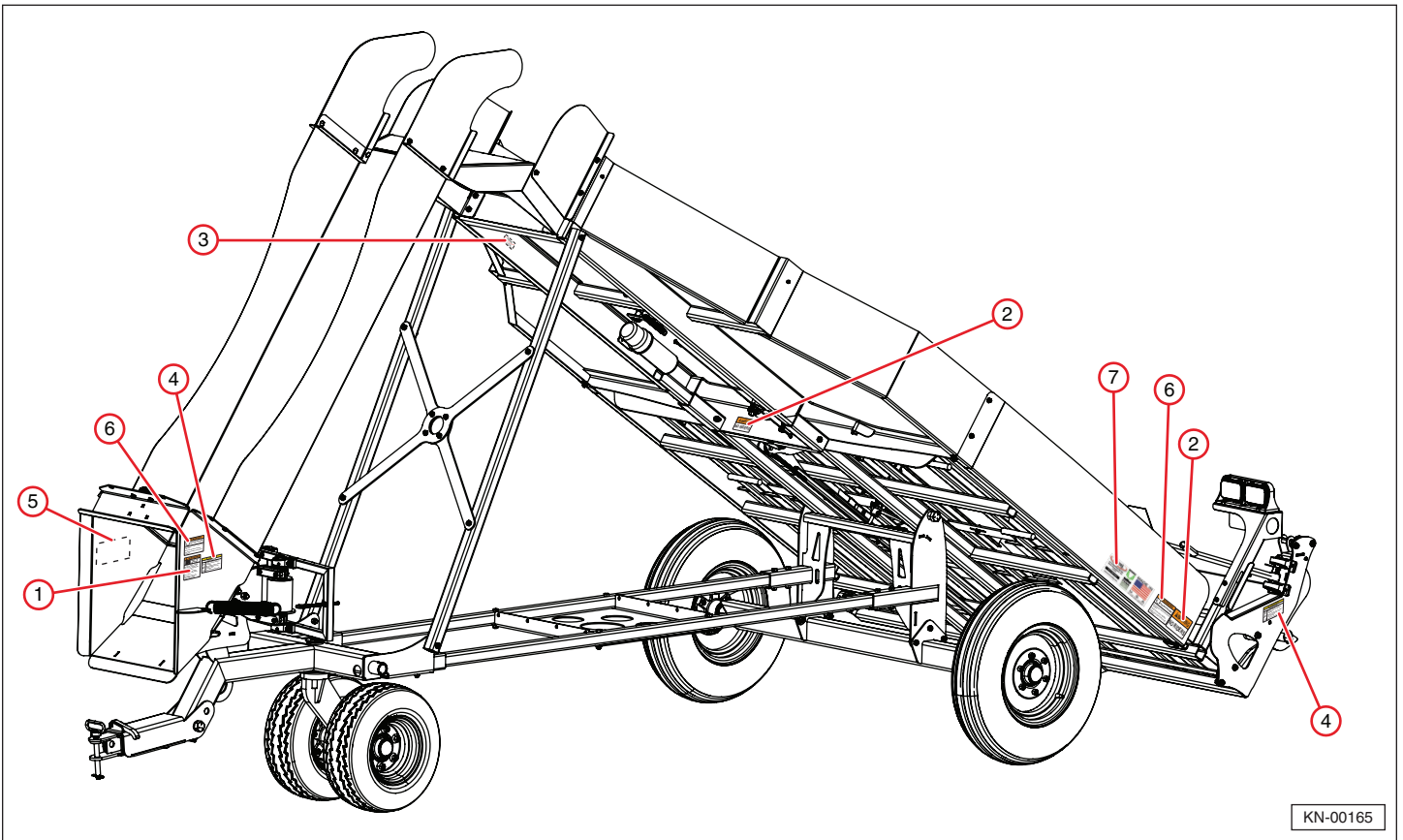

Item	Type	Description	Qty.
1	WARNING	Read the Manual	1
2	WARNING	No Riders	3
3	INFORMATIONAL	Serial Number	1
4	CAUTION	Pinch Point	4
5	WARNING	Do Not Transport at Speeds Over 20 MPH	1
6	WARNING	Falling Hazard	4
7	INFORMATIONAL	Made in USA	1

3.5 Hay Accumulator Safety Signs

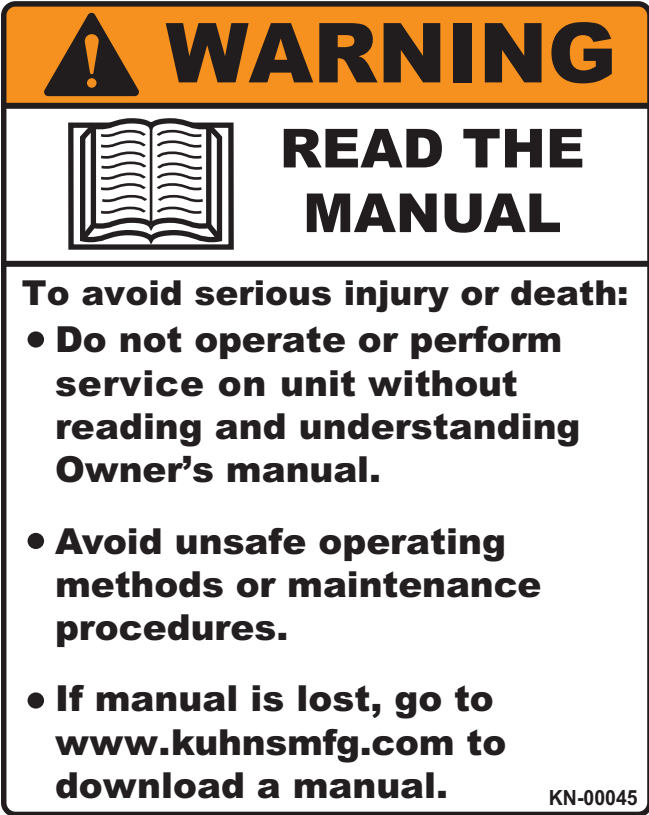
1. 

WARNING

READ THE MANUAL

To avoid serious injury or death:

- Do not operate or perform service on unit without reading and understanding Owner's manual.
- Avoid unsafe operating methods or maintenance procedures.
- If manual is lost, go to www.kuhnsmfg.com to download a manual.

KN-00045

2. 

WARNING

NO RIDERS

KN-00047

3. 

NORDEN MFG

MODEL: XXXXX
SERIAL NO: XXXXX

KN-00049

4. 

CAUTION

PINCH POINT

- Pinch points may cause injuries such as cutting or crushing.
- Do not place hand or fingers between stationary and moving parts.
- Stay clear of moving parts.

KN-00046

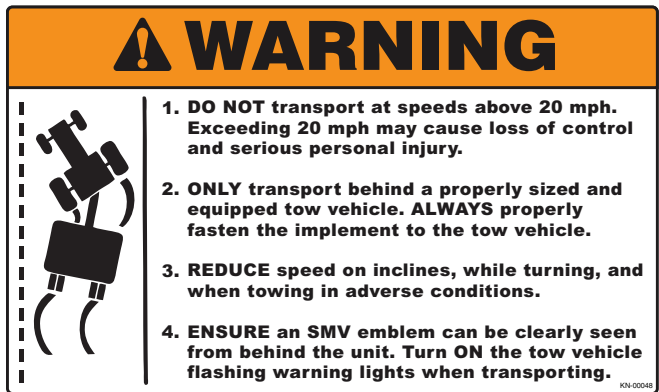
5. 

WARNING

1. DO NOT transport at speeds above 20 mph. Exceeding 20 mph may cause loss of control and serious personal injury.
2. ONLY transport behind a properly sized and equipped tow vehicle. ALWAYS properly fasten the implement to the tow vehicle.
3. REDUCE speed on inclines, while turning, and when towing in adverse conditions.
4. ENSURE an SMV emblem can be clearly seen from behind the unit. Turn ON the tow vehicle flashing warning lights when transporting.

KN-00048

6. 

WARNING

FALLING HAZARD

- Do not climb or stand on the unit at any time.
- Do not use the unit as a platform.
- Falling can result in serious injury or death.

KN-00053

7. 

NORDEN MFG

4210 Kinsman Rd NW
North Bloomfield, OH
44450

(877) 296-5851
www.nordenmfg.com

MEMBER
FEMA
FARM EQUIPMENT
MANUFACTURERS
ASSOCIATION

MADE IN

U S A
WITH SOME GLOBAL COMPONENTS

4. Names of Major Parts

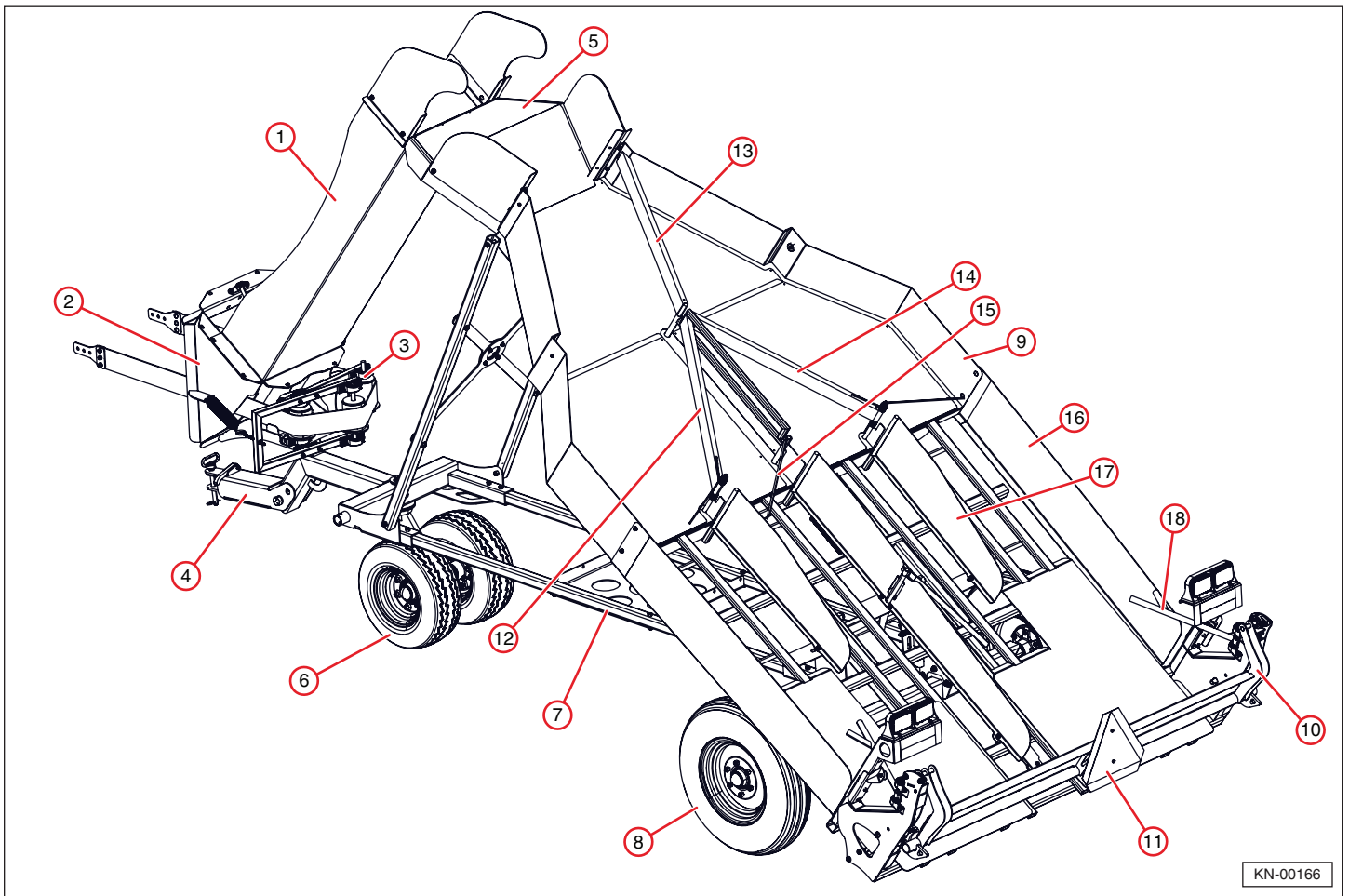

Item	Description
1	Main Chute
2	Belted Base Chute
3	Belt Tensioner
4	Hitch
5	Chute Platform
6	Front Tires, 20.5x8-10
7	Reach Pole
8	Rear Tires, ST225/75R15
9	Accumulator Bed

Item	Description
10	Back Gate
11	Slow Moving Vehicle Sign
12	Gate #1
13	Gate #2
14	Gate #3
15	Gate Switch
16	Side Panels
17	Dividers
18	Swing Arms

4.1 Undercarriage

The Hay Accumulator's undercarriage supports the overall unit and includes the axles, wheel assemblies, swivel dolly, base chute, and hitch.

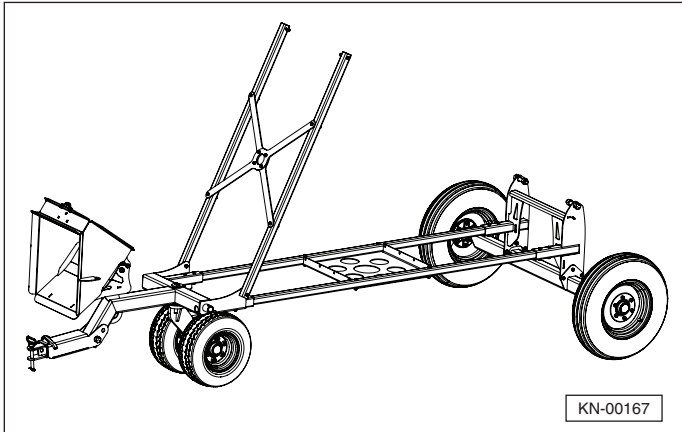

4.2 Accumulator Bed

The accumulator bed guides and positions the bales on the accumulator. The accumulator bed rests on the frame and is secured at the rear of the frame with two heavy-duty hinges. Shipped in the resting position, the bed is lifted upward and fastened for operation and left there.

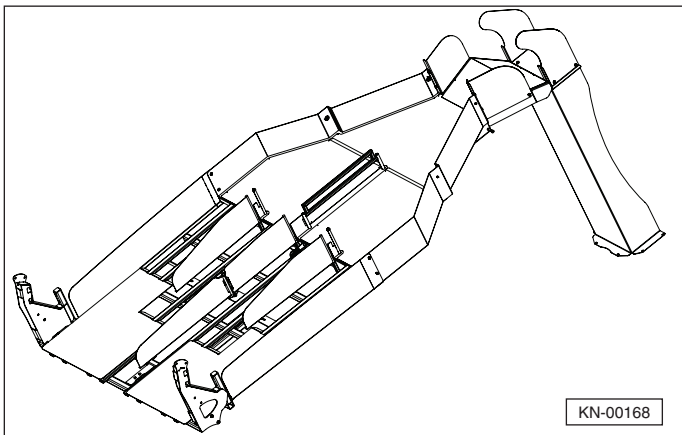

4.3 Linkage System

The linkage system directs the bales through the accumulator bed. The system consists of three gates, a gate switch, two swing arms, a back gate, a trip mechanism, and a network of springs and cables.

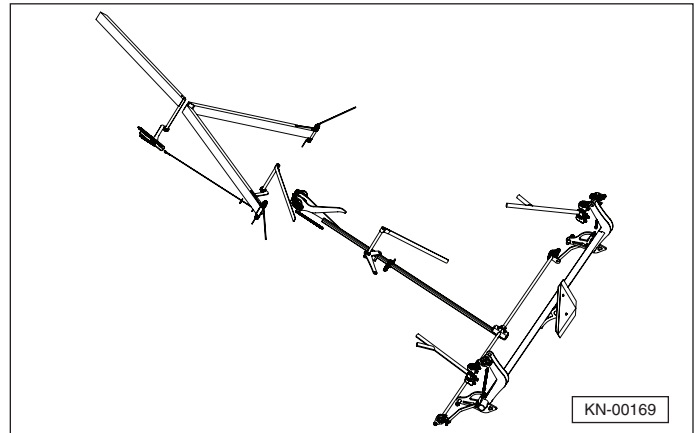

4.4 Belted Base Chute

The belted base chute is standard equipment on the Hay Accumulator and will aid in cornering.

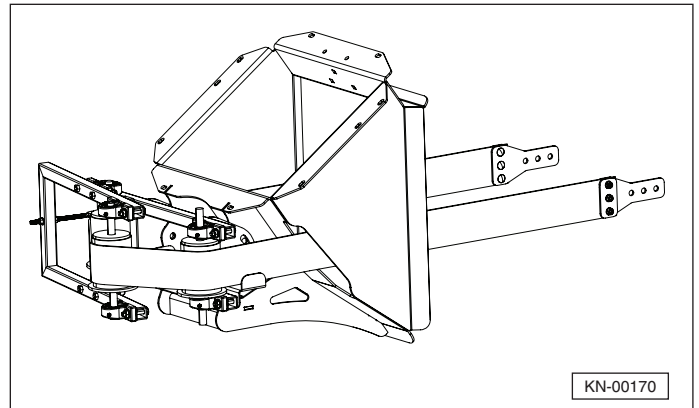

4.5 Lights

The Hay Accumulator is equipped with agricultural lights and an enhanced flasher lighting module to meet ASABE S279 standard.

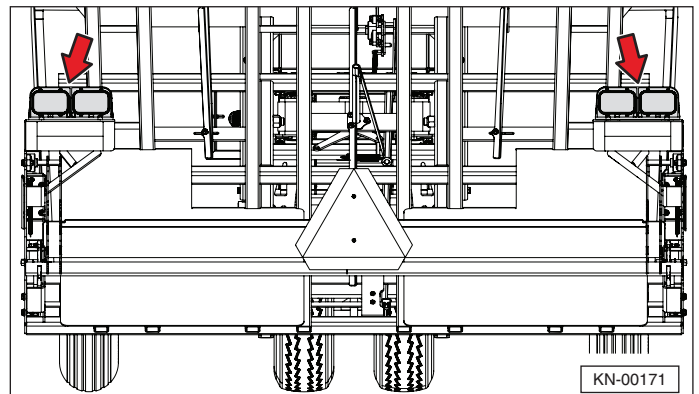

4.6 Linkage System Operation

The AF10 has a spring-loaded swing arm on each side of the accumulator to turn the first and sixth bales sideways.

1. Bale #1 enters the Hay Accumulator and slides downward. As the bale approaches the bottom, it makes contact with the swing arm, turning the bale sideways and into position.

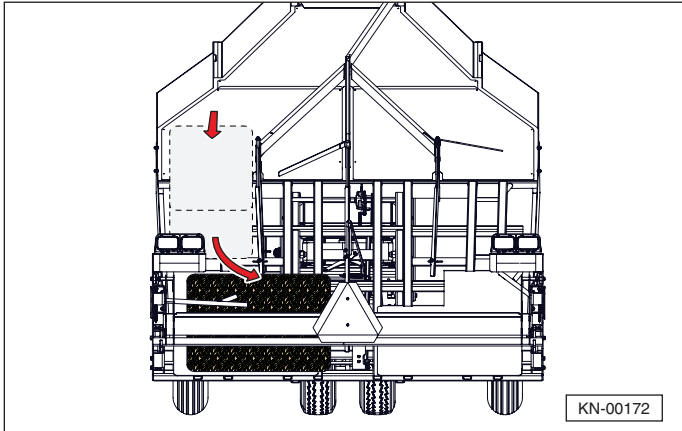

2. Bale #2 enters the Hay Accumulator and slides downward and into position.

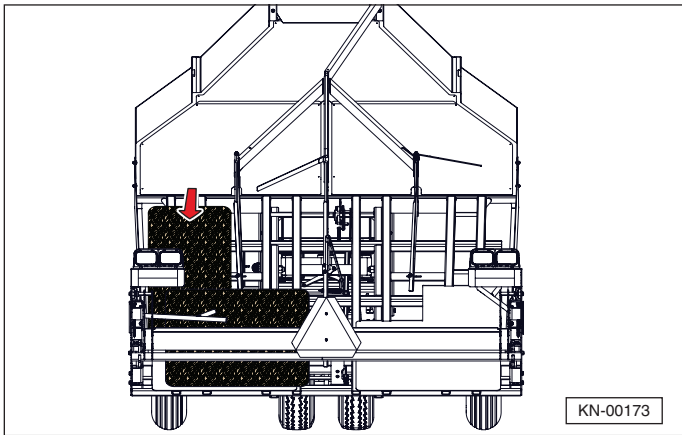

3. Bale #3 enters the Hay Accumulator and slides downward and into position, rotating the gate actuating spring and shifting gate #1 to open row #2.

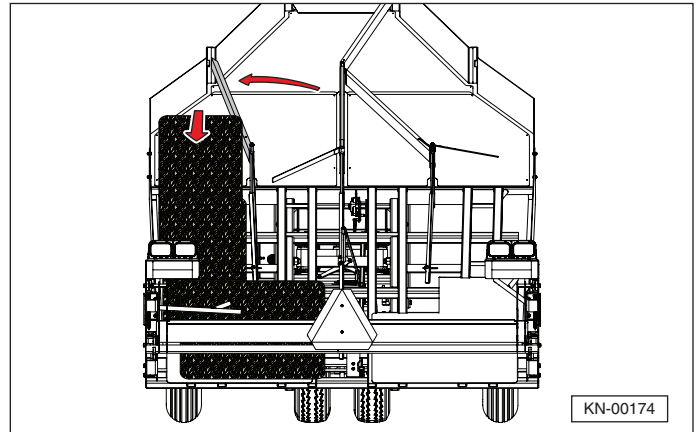

4. Bale #4 enters the Hay Accumulator and slides downward and into position.

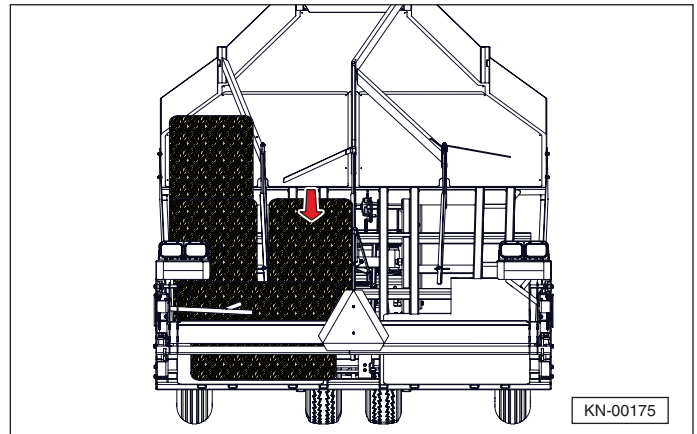

5. Bale #5 enters the Hay Accumulator and slides downward and into position, rotating the gate switch and shifting gate #2 to open row #3.

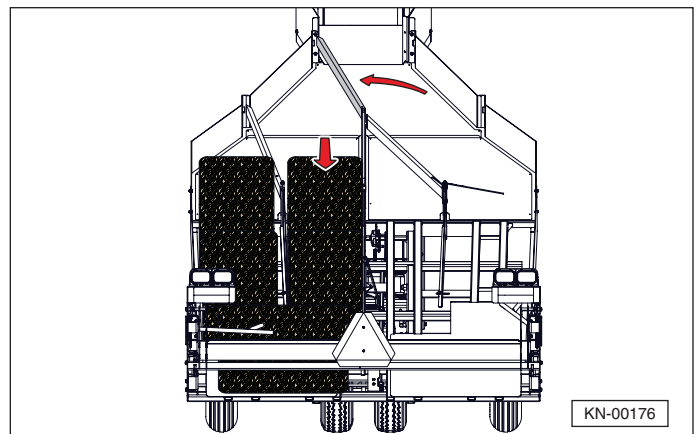

6. Bale #6 enters the Hay Accumulator and slides downward. As the bale approaches the bottom of the bed, it makes contact with the swing arm, turning the bale sideways and into position.

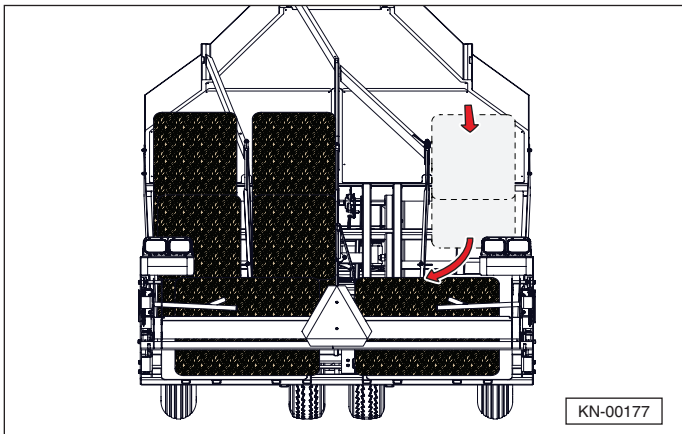

9. Bale #9 enters the Hay Accumulator and slides downward and into position, rotating the back gate trip slider to engage the trip flipper.

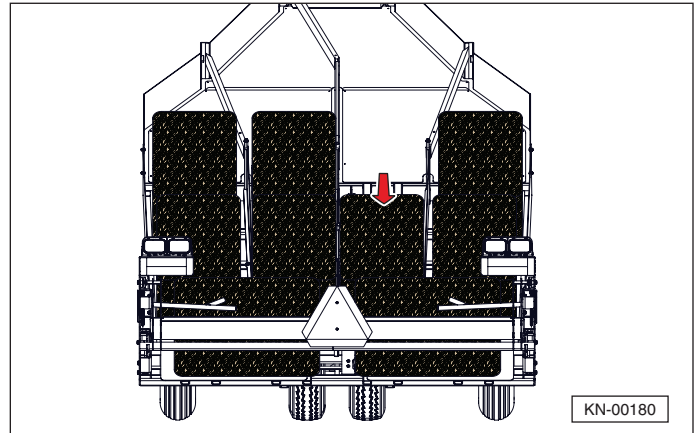

7. Bale #7 enters the Hay Accumulator and slides downward and into position.

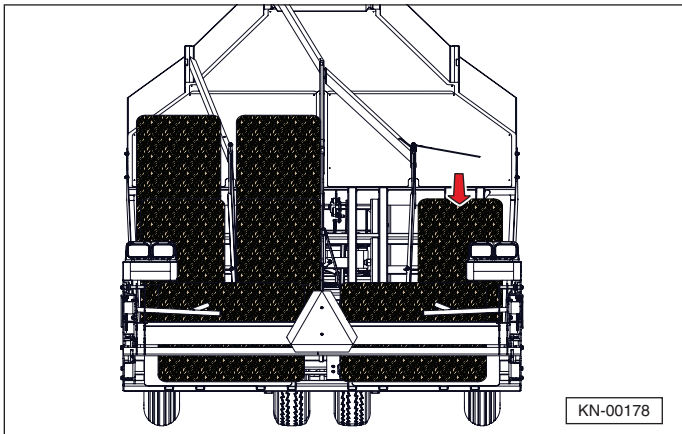

10. Bale #10 enters the Hay Accumulator and slides downward, depressing the back gate trip flipper to open the back gate.

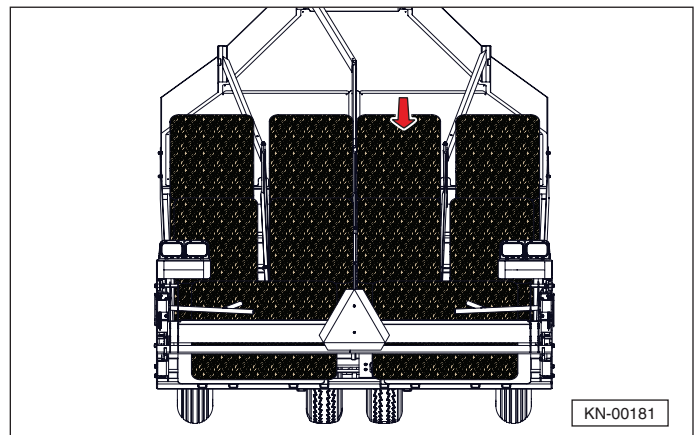

8. Bale #8 enters the Hay Accumulator and slides downward and into position, rotating the gate actuating spring and shifting gate #3 to open row #4.

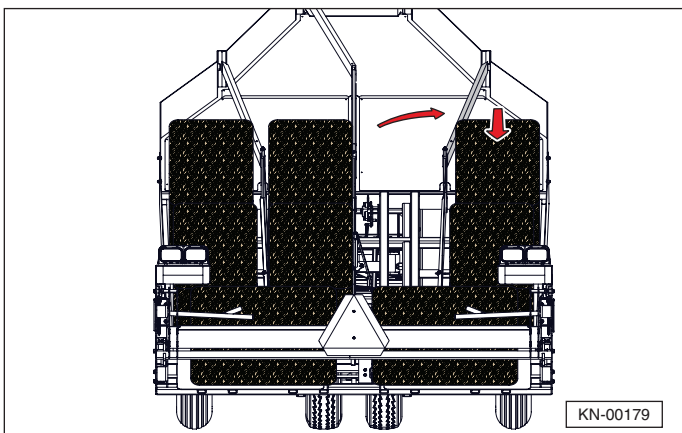

11. Once the back gate is open, the bales drop to the ground. When all bales are clear, the back gate returns to its original position and latches. All gates return to their original position.

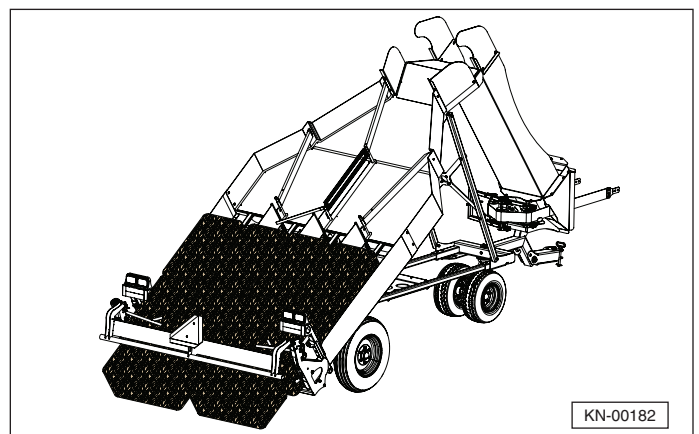

5. Assembly

The accumulator ships in the folded position, as shown.

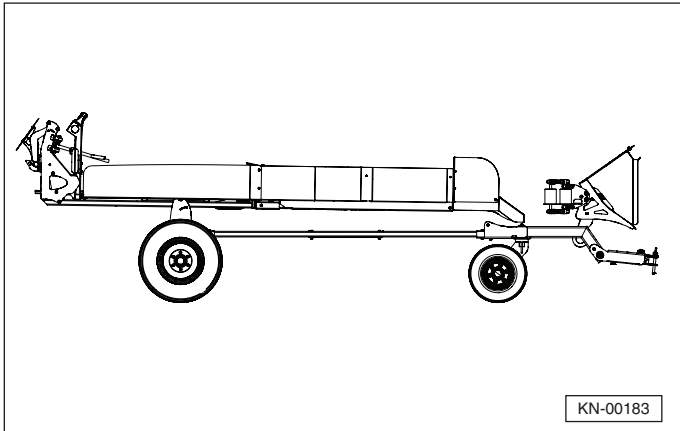

1. Bolt the chute platform into position using four 1/2 x 1-1/4" bolts and lock nuts. Do not fully tighten the bolts.

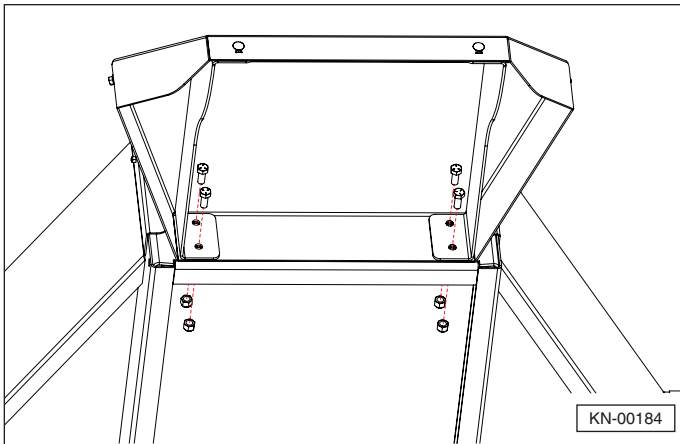

2. Bolt the chute platform sides to the chute platform and the accumulator bed using three 3/8 x 3/4" serrated flange bolts and nuts on each side. Do not fully tighten the bolts.

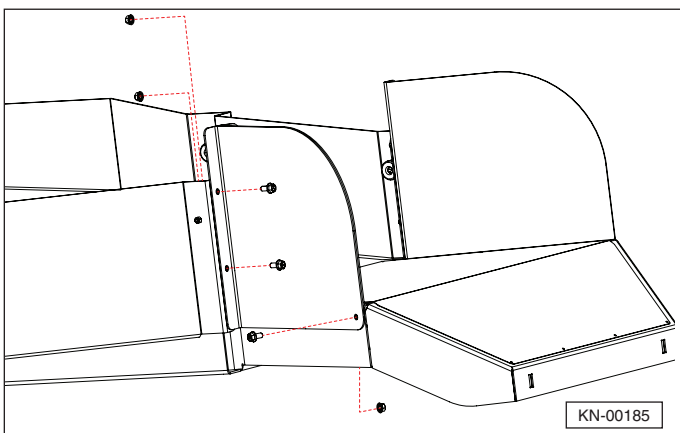

⚠ WARNING



Crush Hazard

The accumulator bed weighs approximately 1270 pounds and can cause serious injury or death if it falls on a person. Use a lifting device with adequate capacity to support the accumulator bed. Use extreme caution when working under the accumulator bed when it is supported by a lifting device. Do not allow anyone to walk under or stand near the accumulator bed when it is supported by a lifting device.

3. Chock the wheels to prevent the accumulator from moving during the next steps.
4. Using a suitable lifting device, raise the front of the accumulator bed to install the front supports. The accumulator bed assembly weighs approximately 1270 pounds.

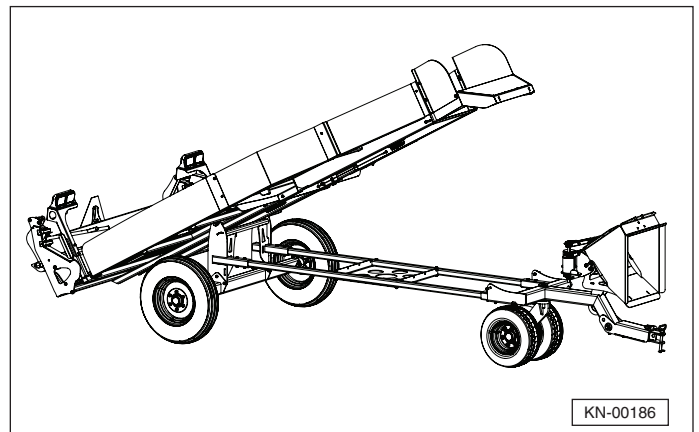

5. Bolt the front supports in place using four 1/2 x 3" bolts and serrated flange nuts provided. Tighten the bolts to the proper torque value.

⚠ WARNING

Make sure to install these bolts from the inside, with the nut on the outside of the accumulator.

Note: Refer to "11.8 Standard Torque Values" on page 39 for the proper torque value for all fasteners.

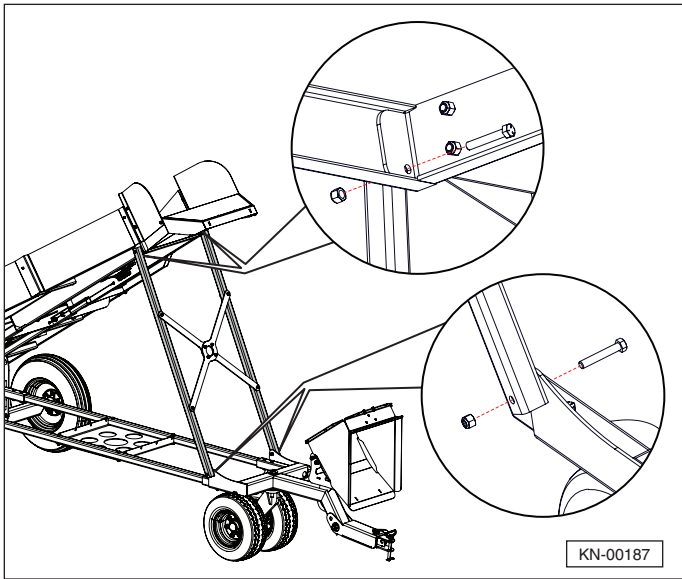

6. Bolt the front crosses in place using four 1/2 x 2-3/4" bolts and serrated flange nuts provided. Do not fully tighten the bolts.

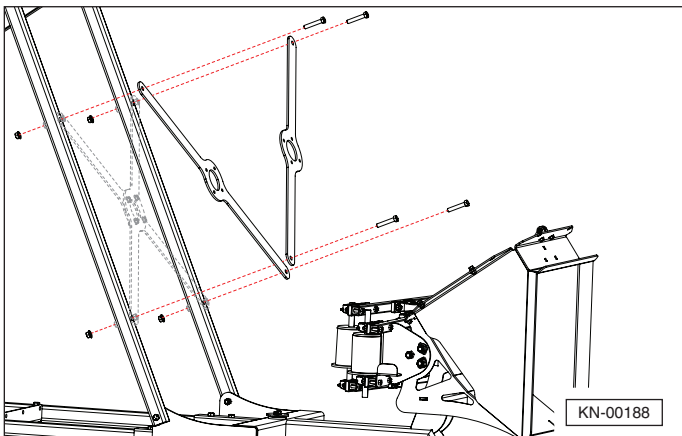

7. Bolt the front crosses together using four 3/8 x 1" bolts and serrated flange nuts provided. Do not fully tighten the bolts.

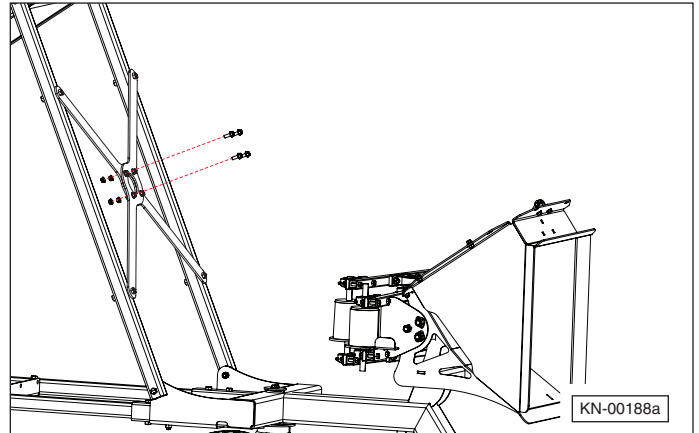

8. If required, bolt the hay dog to the base chute top using two 3/8 x 3/4" serrated flange bolts and nuts.

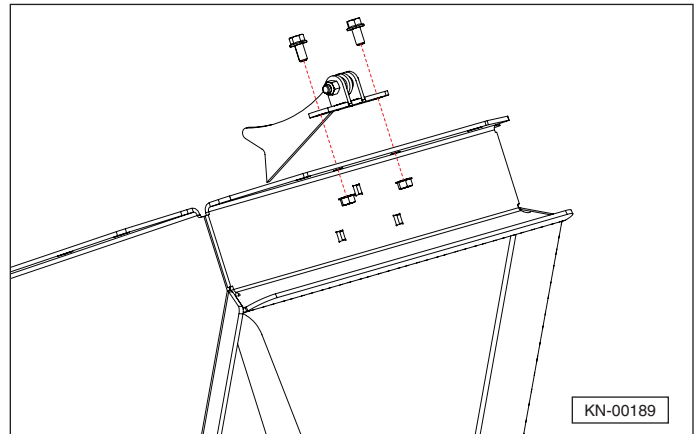

9. Attach the main chute using six 3/8 x 3/4" serrated flange bolts (1) and nuts at the bottom and two 3/8 x 1" carriage bolts (2) with serrated flange nuts at the top. Do not fully tighten the bolts.

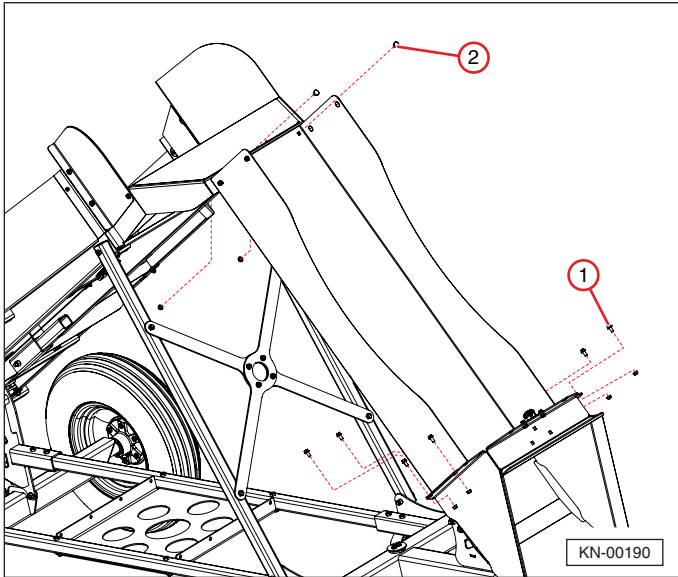

10. Bolt the chute extensions to the main chute using two 3/8 x 3/4" carriage bolts with serrated flange nuts on each side. Tighten the bolts to the proper torque value.

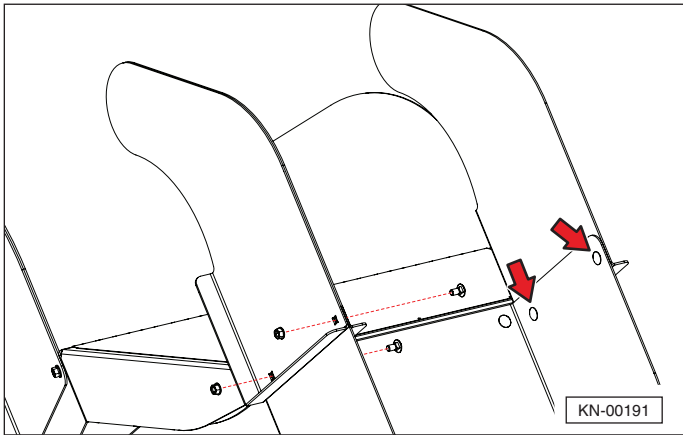

11. Bolt the SMV sign into position using two 5/16 x 3/4" carriage bolts with nylon lock nuts. Tighten the bolts to the proper torque value.

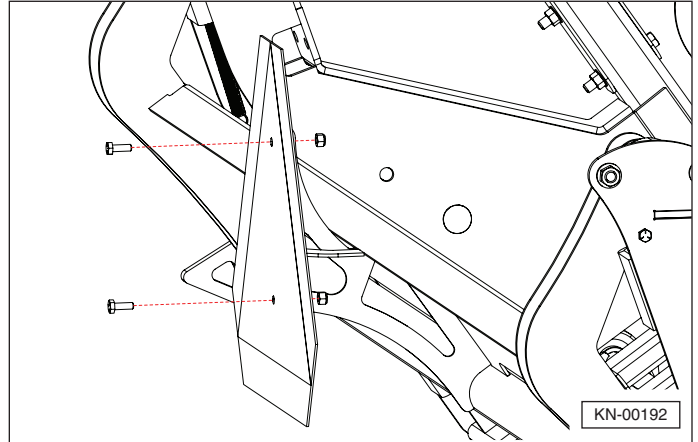

12. Tighten all the bolts that were previously left loose to the proper torque value. Tighten the bolts in the order that they were assembled, as shown.

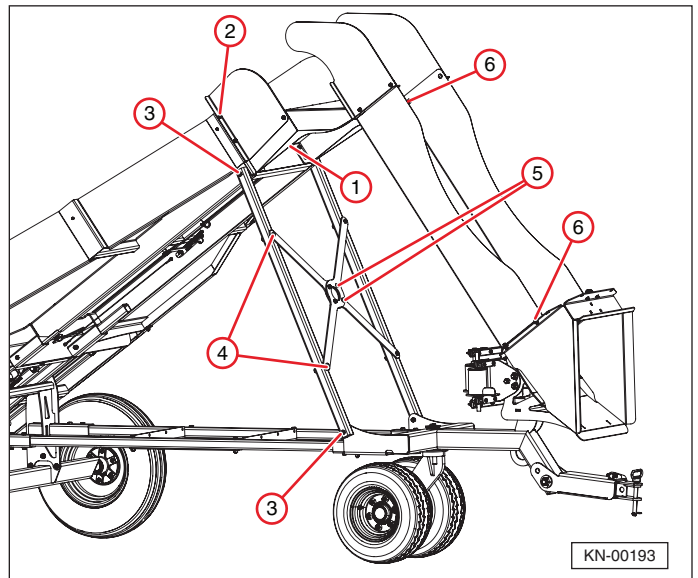

6. Set-up

6.1 User Safety Training

WARNING



Roll Away Hazard

Before leaving the tractor seat, make sure the engine is stopped, the transmission is placed in park, the key is removed, and the parking brake is set.



Crush Hazard

The tractor should be equipped with a Roll Over Protective Structure (ROPS) and a seat belt. A crushing hazard could occur if the driver is ejected from the seat while the tractor is in motion. Fasten the seat belt whenever the tractor is moving.



Crush Hazard

The weight of the tractor, plus the implement, if it rolls onto a person, could cause serious crushing injury or death.



Stay Clear

Keep hands and clothing clear of moving parts. Do not clean, lubricate, or adjust your equipment while it is moving.



Rollover Hazard

To avoid serious injury or death from falling off tractor, equipment runover, rollover, or crushing:

1. Use ROPS equipped tractor.
2. Keep ROPS locked in the UP position.
3. Only operate the equipment when seated in the tractor seat.
4. Always fasten seat belt when operating the tractor.
5. Use caution when transporting over uneven terrain and slow down for turns.

The tractor must be equipped with a Roll Over Protective Structure (ROPS) (tractor cab or roll bar) and seat belt to protect the operator from falling off the tractor, especially during a roll-over where the driver could be crushed and killed. Only operate the tractor with the ROPS in the raised position and seat belt fastened.

SAFETY INSTRUCTIONS

The following safety instructions are provided to help prevent injury or limit equipment damage.



Train Unfamiliar Users

It is the owner's responsibility to make sure any person using the Hay Accumulator, especially if it is loaned or rented, has been thoroughly trained on its proper and safe use.

Be certain only physically-able persons will use the Hay Accumulator.



Users who have not read and understood all operating and safety instructions are not qualified to use the Hay Accumulator.

If the elderly are assisting with the work, their physical limitations need to be recognized and accommodated.

Never allow children to operate equipment.

6.2 Tractor Requirements



  **Tractor Owner/Operator Manual**
Always refer to the tractor owner's manual to ensure compatibility and maximum safety.

Refer to the tractor and baler Operator's Manual to make sure the tractor used has the power to pull and operate the baler. There is no extra horsepower required for the Hay Accumulator, other than towing.

Operating the baler with a tractor that does not have adequate power may damage the tractor engine.

Operating the equipment with a tractor that does not meet the following requirements may cause tractor or implement damage and be a potential danger to the operator and passersby.

Always review the "controls" section of the tractor Operator's Manual to be familiar with the location, settings, and function of the tractor controls. Be familiar with all controls before using this equipment.

6.2.1 Equipment and Capabilities

- Approved Roll-Over Protective Structure (ROPS) or ROPS cab and seat belt.
- Tractor Safety Devices; Slow Moving Vehicle (SMV) emblem, lighting, PTO master shield.
- Front end weight, as needed, to maintain 20% weight on front axle.
- To reduce the risk of fire, do not use a tractor with an underframe exhaust.
- A loader with at least 1700 lb. lift capacity is required to handle the grouped bales.

6.2.2 Tractor Safety Devices

If transporting or operating the tractor and implement on a public roadway, the tractor and/or implement must be equipped with proper warning lighting and a Slow Moving Vehicle (SMV) emblem, which are clearly visible from the rear of the unit. Lights and a SMV emblem must be attached directly to the implement if the visibility of the tractor warning signals are obscured.

Maintain all manufacturer-equipped safety shields and guards. Always replace shields and guards that were removed for access to connect, service, or repair the tractor or implement. Never operate the tractor PTO with the PTO master shield missing or in the raised position.

6.3 Baler Hitch Setup

CAUTION

 Use caution when connecting the accumulator to the baler. The Hay Accumulator wheels should be securely chocked. Keep hands and feet clear of pinch points between the baler drawbar and Hay Accumulator.

Proper baler hitch set up is essential to successful cornering with the Hay Accumulator.

1. Make sure the baler and Hay Accumulator are on level ground, and remove all chutes/mechanisms from the back end of the bale chamber.
2. Assemble the three piece chamber extension using six 3/8 x 1" flange bolts and 3/8" flange nuts provided. Do not fully tighten the bolts at this time.

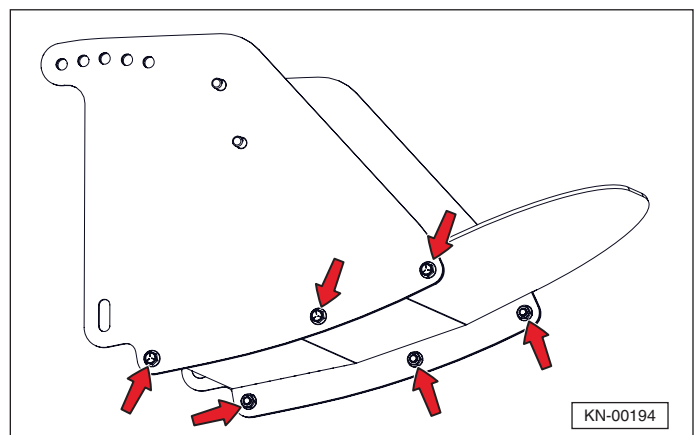

3. Loosely bolt the chamber extension onto the baler using four 3/8 x 1-1/4" carriage bolts and 3/8" flange nuts provided. Make sure the carriage bolt heads are on the inside.

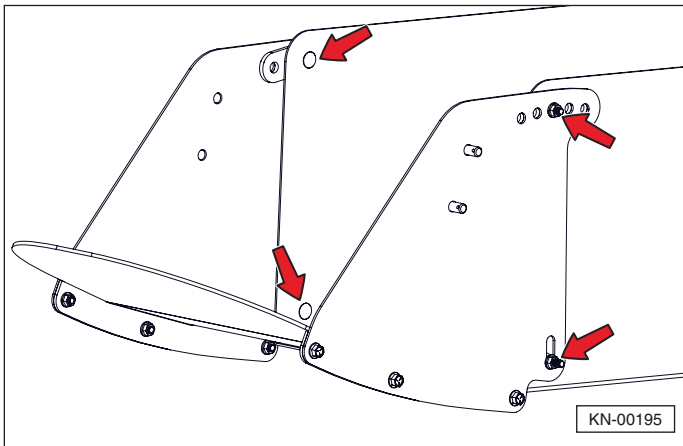

4. Set the length of the baler hitch so that the hitch pin is 0 to 2" behind the tip of the chamber extension. If necessary, add a hitch length setting by drilling a hole in the drawbar. The hitch must be centered left/right below the chamber. If it is not centered, you will need a Norden New Holland® centering hitch adapter. Some John Deere® balers may need a hitch extension for the proper hitch length.

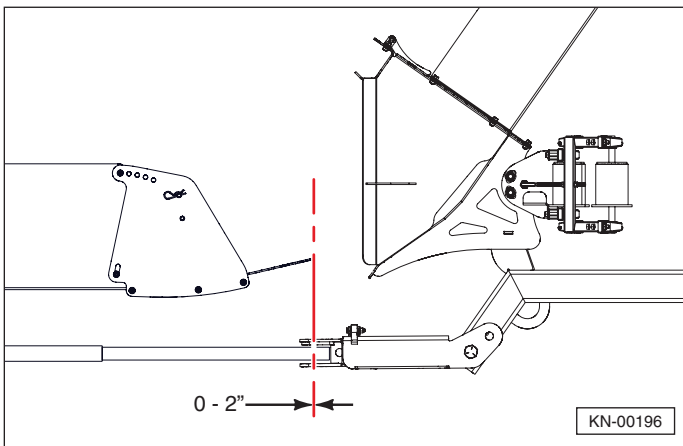

5. Select one of the five holes on the adjustable bale chamber extension that will best guide the bales into the Hay Accumulator base chute.
 - a. For the initial adjustment, select the hole that aligns the bottom plate of the bale chamber extension to a point 8-10" back from the base chute bottom edge, as shown below. This can be fine-tuned later if needed to achieve optimum results.
 - b. If there is a gap between the bale chamber and the chamber extension, use washers (not included) as spacers.

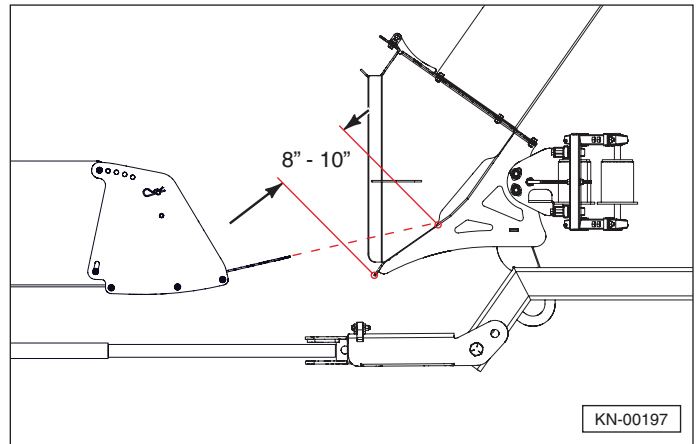

6. Tighten the four carriage bolts on the sides of the chamber extension, then the six flange bolts on the bottom.

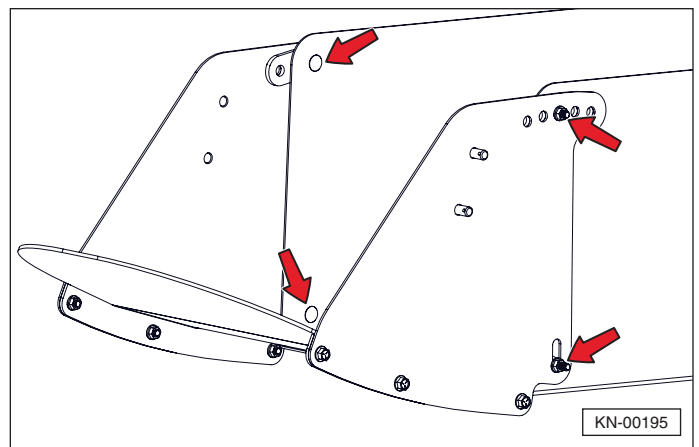

7. On level ground, route the belt through the slots in the base chute, and fasten the belt plates to the pins on the side of the chamber extension. There are two sets of pins; use the set that makes the belt most nearly level.

Note: Position the belt with the large belt plate next to the chamber extension.

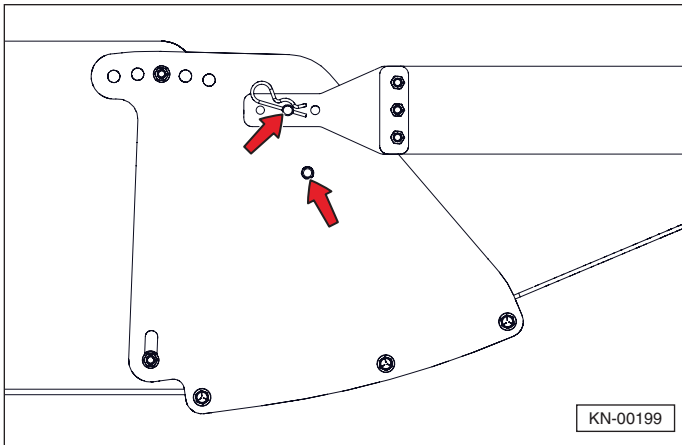
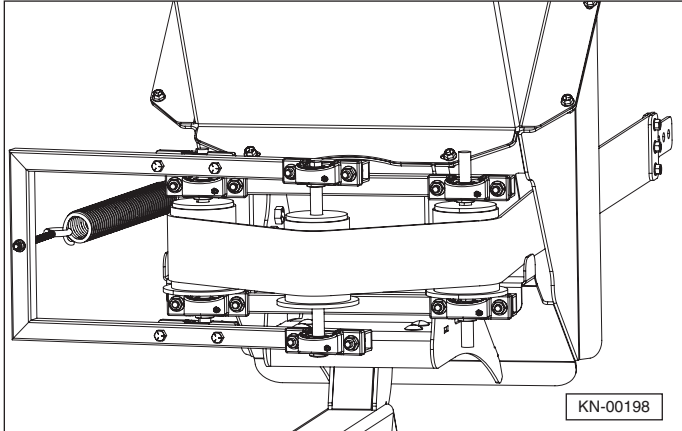

8. Ensure that the belt tensioner assembly is square with the belt by adjusting the angle of the belt tensioner assembly at its mounting point on the base chute.

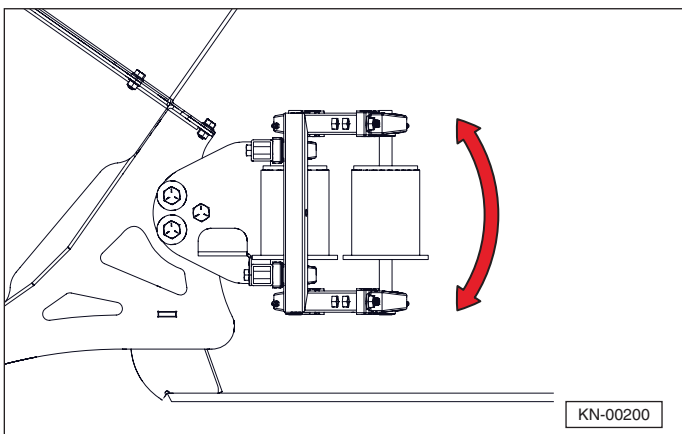

9. The belt tension is correct when the center of the tensioner roller is roughly 4 to 6" behind the centers of the other rollers. It will be necessary to install the second end plate on the belt in the correct position to achieve this condition.

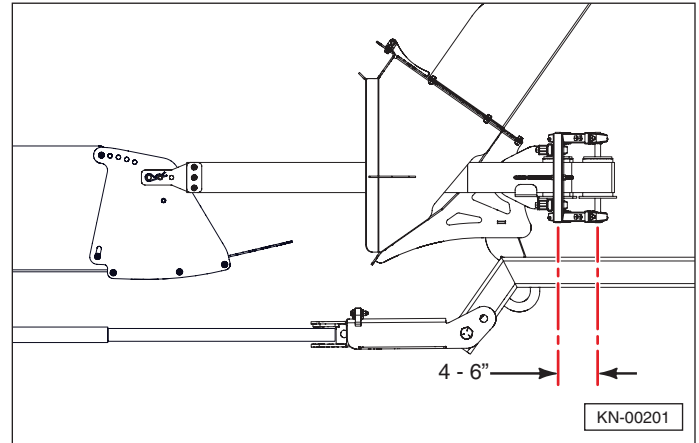

Note: The next three steps are much easier with two people.

10. Unhook the tensioner spring, and hold the tensioner at the correct position.

11. Using the middle hole, temporarily mount the large end plate on the appropriate pin.

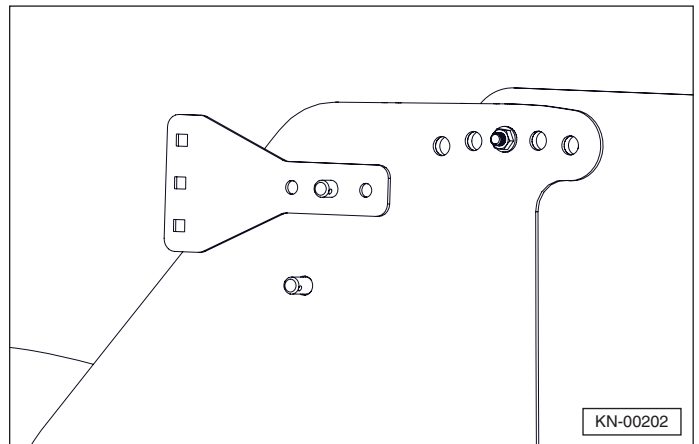

12. Hold the belt on the outside of the large end plate, pull the belt snug, and mark a line on the belt even with the back end of the plate.

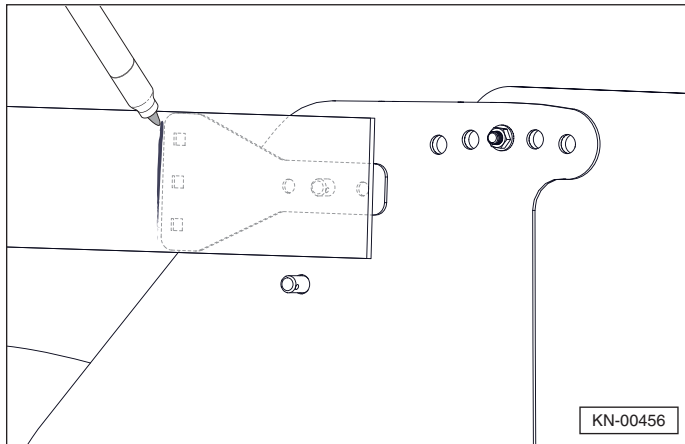

13. Place the belt on a flat surface. Remove the large end plate from the pin and place it on the belt with the back edge on the previously-marked line. Mark the hole locations.

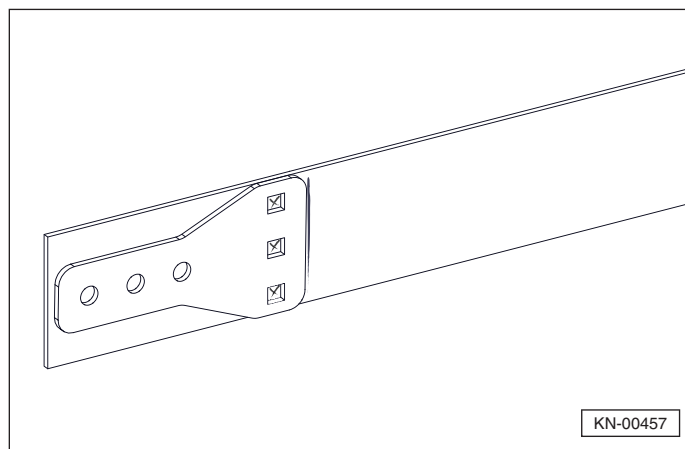

14. Use a 3/8" leather punch or a 7/16" drill to make three holes through the belt at the marked locations.

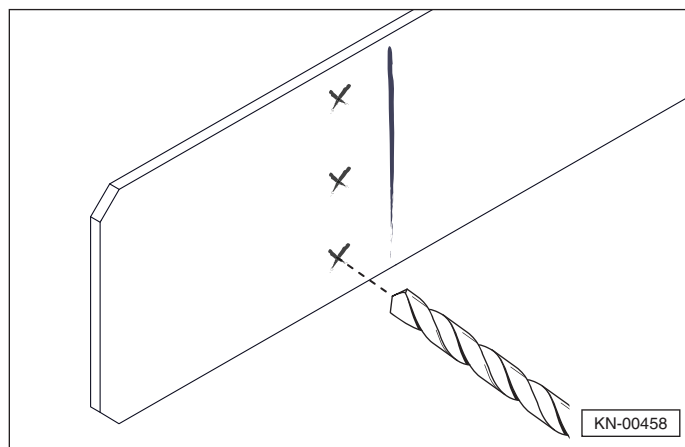

15. Install the belt end plates using three 3/8 x 1" carriage bolts and flange nuts. Position the large end plate on the inside (nearest to the bale chamber). Remove the excess belt length.

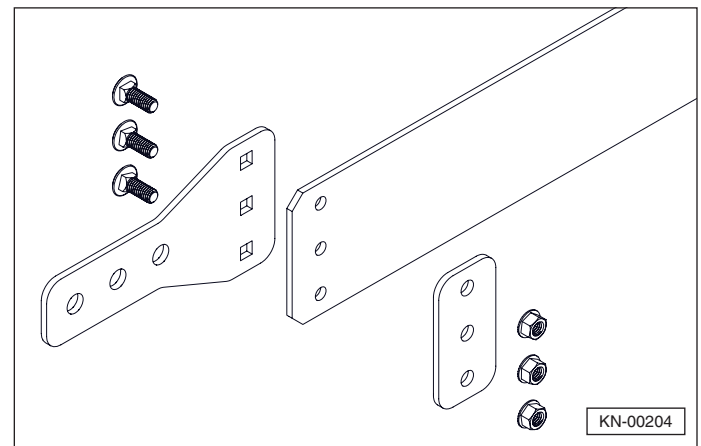

16. Re-attach the tensioner spring, and fasten the belt plates to the appropriate pins on the side of the chamber extension.

6.4 Baler Chamber Settings

This is dependent on your requirements for the size of bale that you want to make. First loosen the bale chamber nearly all the way to compensate for the back pressure caused by the chute. You can then adjust the chamber pressure to reach the desired bale size. You may need to remove all the wedges from the chamber.

6.5 Baler Hitch Special Requirements

6.5.1 Older New Holland® (NH) Balers

1987 and older NH balers have the hitch on the right hand side of the chamber. Norden Mfg. offers a center hitch adaptor to center the hitch.

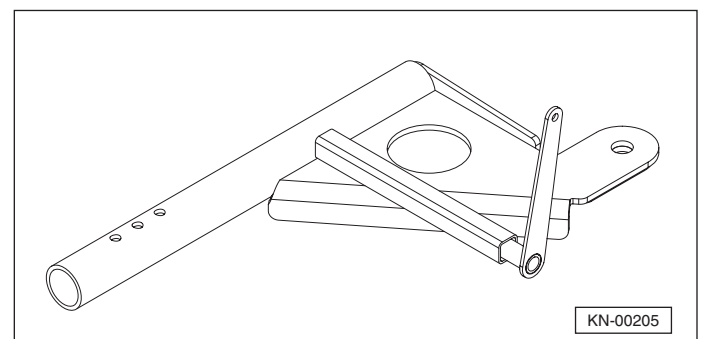

6.5.2 Newer New Holland® Balers

Newer NH balers have a hitch centered underneath the chamber. The hitch may need to be modified to meet the dimensions given in “6.3 Baler Hitch Setup” on page 22.

SAFETY INSTRUCTIONS

Consult the baler manufacturer before making any modifications to the baler.

6.5.3 John Deere® (JD) Balers (1988 and newer)

The hitch on the JD baler may need to be extended to meet the dimensions given in “6.3 Baler Hitch Setup” on page 22. Norden Mfg. offers a special hitch extension for John Deere® balers.

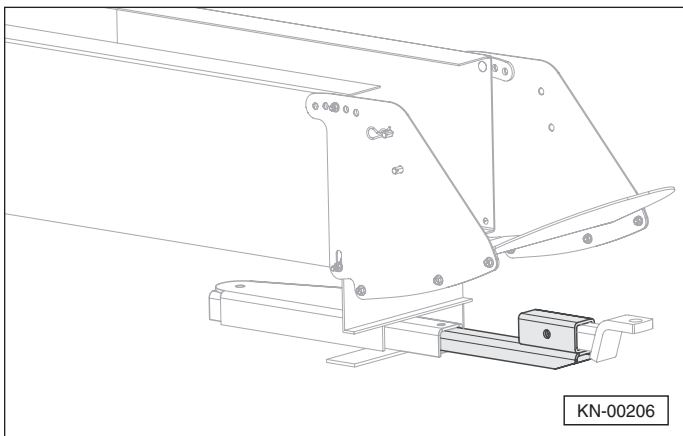

6.5.4 Inline Balers

Inline balers should need little or no modifications.

6.6 Lighting Socket Holder

A lighting socket holder is supplied to support the light socket. It is designed to bolt to the side of the chamber extension or the baler.

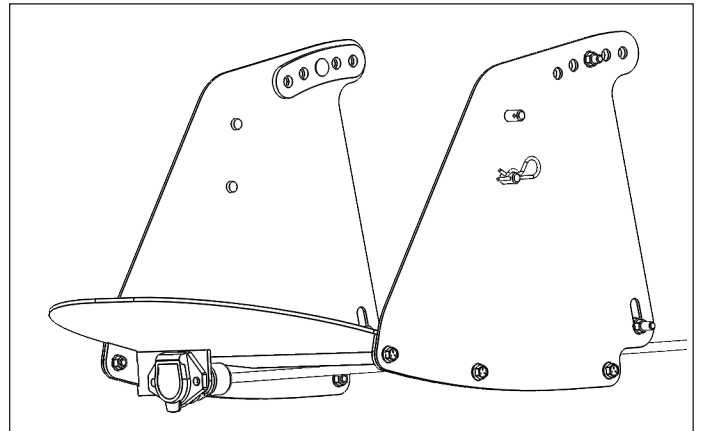

If bolting to the chamber extension, it can use one of the lower bolts that hold the chamber extension in place.

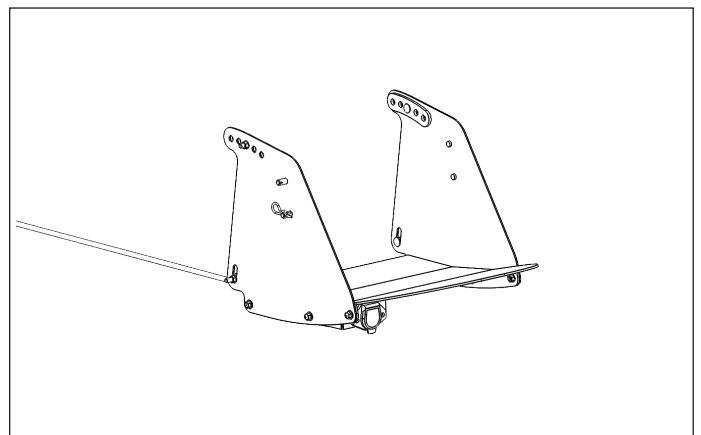

7. Operation

7.1 Operating Safety

WARNING



Roll Away Hazard
Never leave equipment running unattended.

When halting operation, even for a short time, set the tractor or towing vehicle brakes, disengage the PTO, shut off the engine, and remove the ignition key.







Fall Hazard
Do not climb or stand on the Hay Accumulator for any reason. Falling can result in serious injury or death.



Overturn Hazard
DO NOT operate on steep slopes as overturn may result. Overturn can result in serious injury or death.

SAFETY INSTRUCTIONS

-  Be especially observant of the operating area and terrain – watch for loose fill, holes, rocks, or other hidden hazards. Always inspect the area prior to operation.
-  Pick the most level route when transporting across fields. Avoid the edges of ditches or gullies and steep hillsides. Be extra careful when working on inclines.
-  Periodically clear the Hay Accumulator of loose hay to prevent buildup of dry, combustible materials. Do not climb or stand on the accumulator to remove a bale.
-  Maneuver the tractor or towing vehicle at safe speeds.
-  Allow for the unit's length when making turns.

7.2 Pre-Operation Checklist

Before each use of the accumulator, the following areas should be checked.

Checklist Before Each Use	
4	Task
	Make sure the Hay accumulator is positively attached to the baler drawbar. Refer to "7.3 Attaching to Baler" on page 27.
	Make sure the tires are inflated properly and the lug nuts are tight.
	Check the condition of the belt.
	Visually inspect the Hay Accumulator for any loose bolts, worn parts or cracked welds, and make necessary repairs.
	Make sure all retainer clips and pins are in place.
	Make sure the belted base chute tensioner and end gate operate freely.
	Make sure the operating area is clear, especially of children and animals.

7.3 Attaching to Baler

Use caution when connecting the Hay Accumulator to the baler. Keep hands and feet from under the equipment and clear of pinch points between the drawbar and accumulator hitch.

WARNING

 **Crush Hazard**
Crush hazard between hitch and implement. Do not allow anyone to stand between the hitch and implement during hook-up operations.

 Use caution when connecting the accumulator to the baler. The Hay Accumulator wheels should be securely chocked. Keep hands and feet clear of pinch points between the baler drawbar and Hay Accumulator.

- Board the tractor and start the engine. Back the baler up to the accumulator hitch until the holes in the drawbar and clevis are aligned.
- Stop the tractor, place the transmission in park or neutral, apply the parking brake, shut down the engine, and remove the key. Wait for all motion to come to a complete stop before exiting the tractor.
- Insert a high strength drawbar pin through the clevis and drawbar holes and install the retaining pin. Do not use a homemade or shop made pin.

▲ WARNING



Crush Hazard

Unexpected separation of the accumulator from the baler could cause death or serious injury. Use only an OEM high strength drawbar pin. Do not use a homemade or shop made pin.

4. Fasten the guide belt plates to the pins on the side of the chute extension using the hairpin retainers.

7.3.1 Break In

To quickly and effectively “break in” the Hay Accumulator, apply cooking spray to the surface of the bed to make the bales slide easier. After a couple dozen bales have been through the Hay Accumulator, the surface will be buffed enough to slide without spray.

7.3.2 Stuck Bale Removal

If a bale should get caught in the chute, stop baling, place the transmission in park or neutral, apply the parking brake, shut down the engine, and remove the key. Wait for all motion to come to a complete stop before exiting the tractor to safely remove the bale. Use a pole, broomstick, or other suitable tool to remove the bale. **Do not climb or stand on the accumulator to remove a bale.**

If the bale cannot be manually dislodged, break the bale and remove the loose hay from the accumulator.

▲ WARNING



Fall Hazard

Do not climb or stand on the accumulator for any reason. Falling can result in serious injury or death.

7.4 Operating Procedures

7.4.1 Cornering

When properly set up, the Hay Accumulator will corner without difficulty. If the hitch configuration is not as specified in this manual, problems may occur. Refer to “6.3 Baler Hitch Setup” on page 22. Once you have ensured that everything is properly configured, if you are still experiencing trouble, contact Norden Mfg for additional help.

7.4.2 Hillsides

▲ WARNING



Overturn Hazard

DO NOT operate on steep slopes as overturn may result. Overturn can result in serious injury or death.

The Norden Hay Accumulator works well on moderate hillsides. Operate up and down (not across) intermediate slopes. Avoid sudden starts and stops. If problems persist, call Norden Mfg. for service.

7.4.3 High Moisture Hay

The Norden Hay Accumulator bed floor is covered with stainless steel to help the bales slide. Baling hay with a moisture content of 25% or over is not recommended.

7.5 Detaching From Baler

Use caution when disconnecting the Hay Accumulator from the baler. Keep hands and feet from under the equipment and clear of pinch points between the drawbar and Hay Accumulator hitch.

▲ WARNING



Crush Hazard

Crush hazard between hitch and implement. Do not allow anyone to stand between the hitch and implement while detaching the Hay Accumulator.

1. Park the tractor, place the transmission in park or neutral, apply the parking brake, shut down the engine, and remove the key. Wait for all motion to come to a complete stop before exiting the tractor.
2. Chock the Hay Accumulator wheels before attempting to disconnect it from the baler. Use extreme care to keep feet and hands clear of any pinch points caused by the drawbar and hitch.
3. Detach the guide belt from the pins on the sides of the bale chamber.
4. Remove the drawbar pin from the clevis and drawbar.
5. Board the tractor and start the engine. Drive the tractor and baler away.

8. Troubleshooting

8.1 Front Gate Bounces in Home Position

If the front gate bounces away from the right bumper and catches bales, more return spring tension is needed.

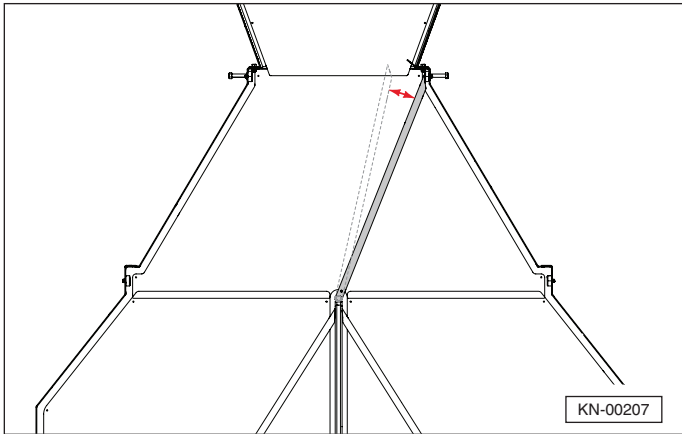

1. Loosen the two screws on the split collar and rotate the gate arm downward (clockwise).

Note: The factory setting for the return spring length is 10-3/8".

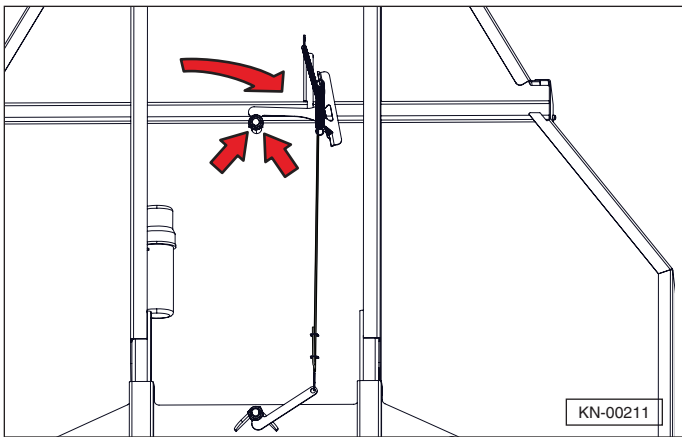

2. Shorten the cable to maintain the same position for the switch arm.

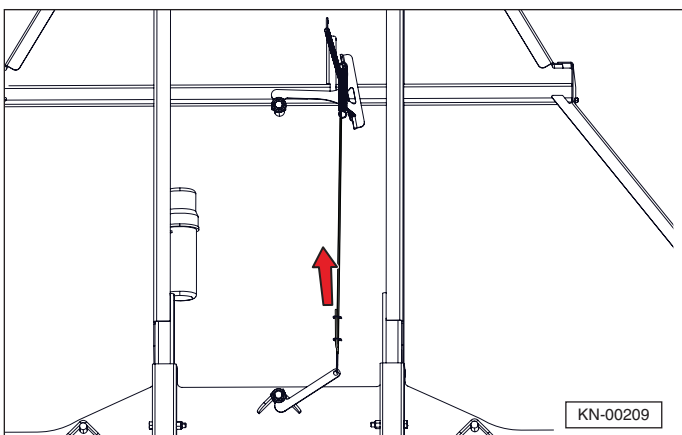

8.2 Front Gate Bounces in Open Position

If the front gate bounces away from the left bumper and catches bales, more opening spring tension is needed.

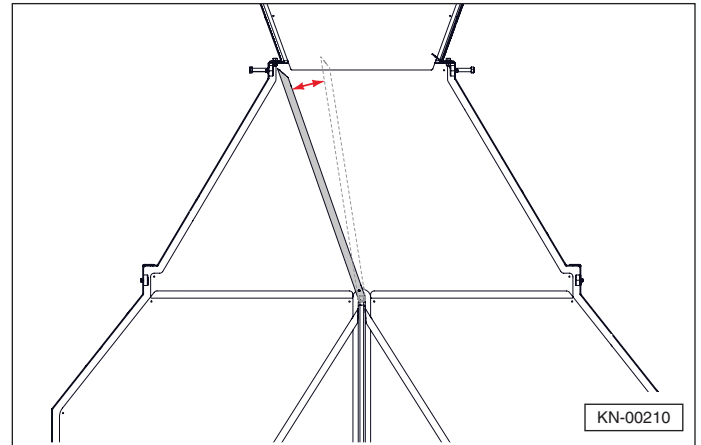

1. Loosen the two screws and rotate the gate arm upward (counterclockwise).

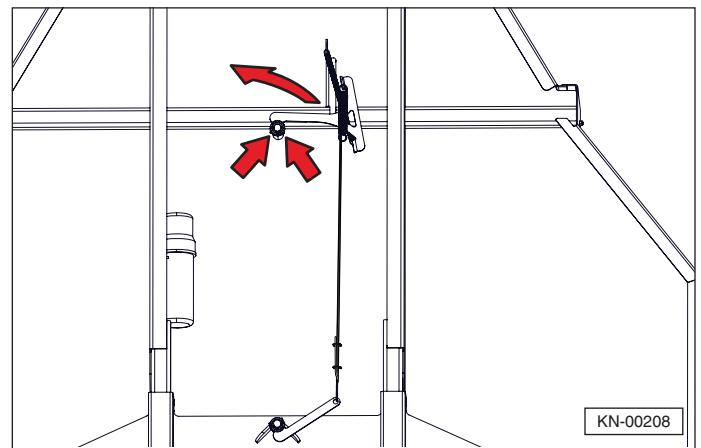

2. Lengthen the cable to maintain the same position for the switch arm.

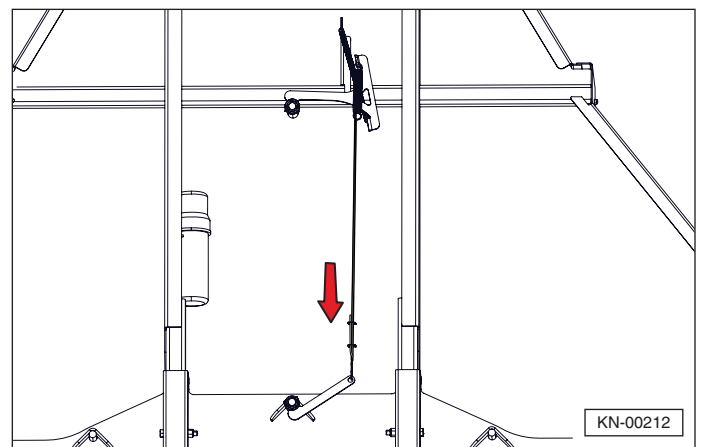

8.3 Back Gate Trip Adjustments

1. The back gate trip reach (1) moves laterally to engage the pin on trip flipper (2). It must move easily and be free of any obstruction. If the back gate fails to open, check for hay or other material blocking the motion of the trip reach.

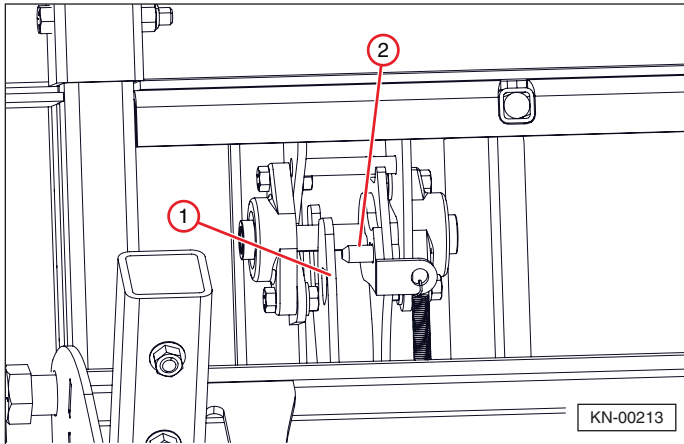

2. When the trip reach is pushed over to the right by trip slider (3), it must not contact the bolt heads (4) on the bearing mount. Make sure there is clearance to the bolt heads when the trip reach is in contact with the trip slider.

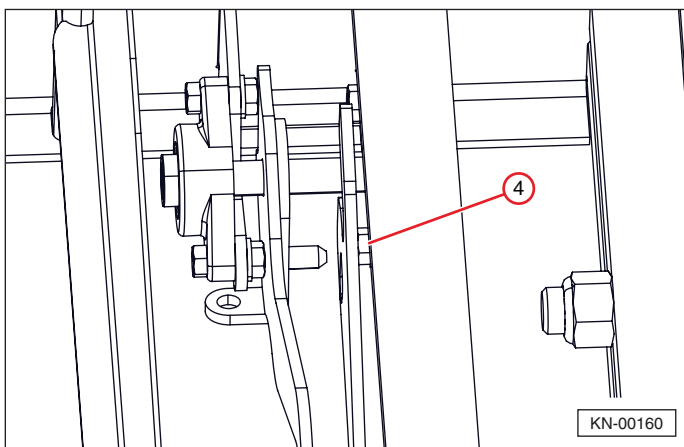
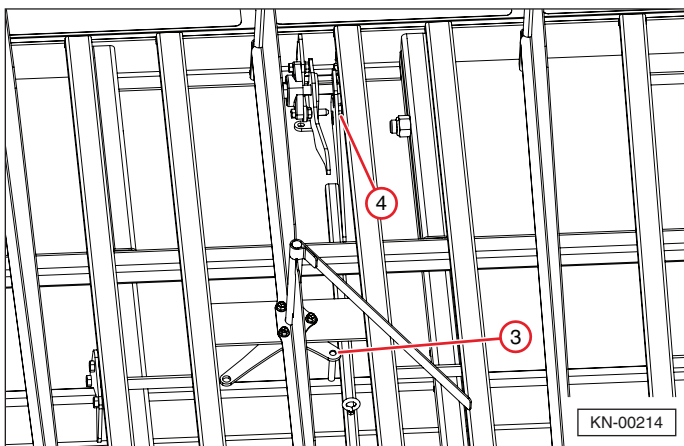

3. The trip reach should engage the pin at the forward edge of the slot. If it engages near the rear of the slot, there may not be enough travel to release the gate.

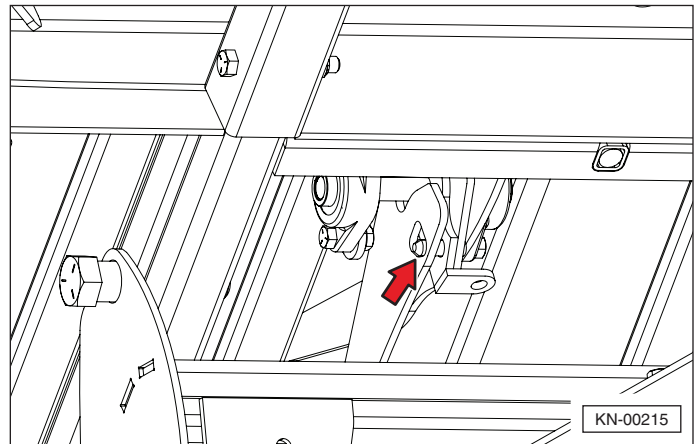

4. To adjust the trip reach, loosen the four bolts on the backshaft ear. Rotate the ear to adjust the front to back position of the trip reach. Slide the ear left or right to adjust the lateral position of the trip reach.

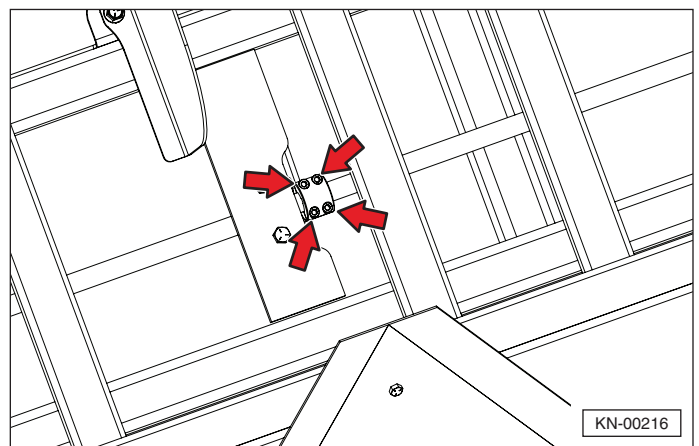

8.4 Swing Arms

The AF10 is equipped with two swing arms at the rear of the accumulator bed that turn bales #1 and #6 to create a tie row. The swing arms must be properly adjusted.

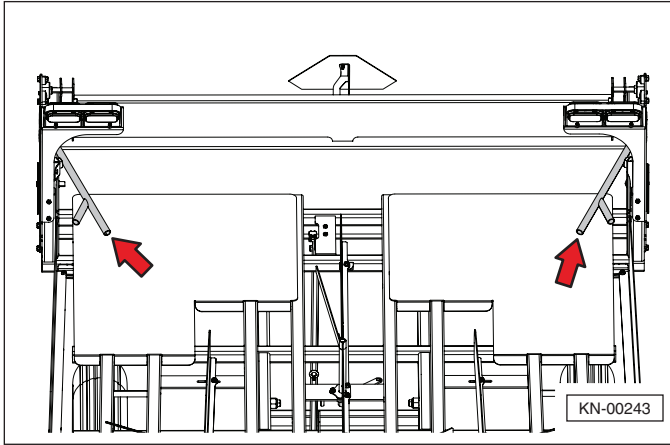

2. The tip of the main tube on the swing arm should be 11-1/2" on center off of the surface of the accumulator bed.

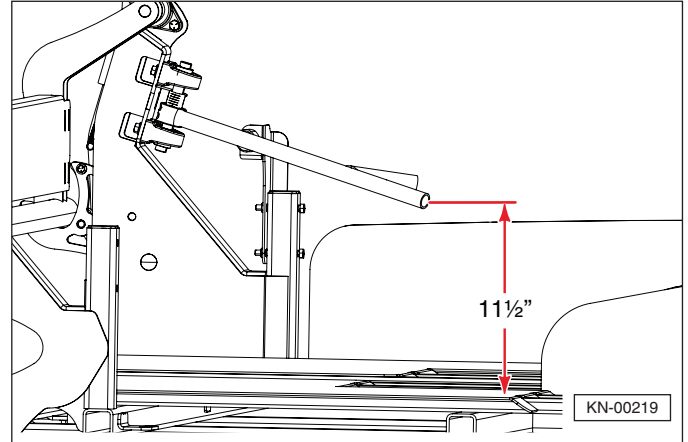



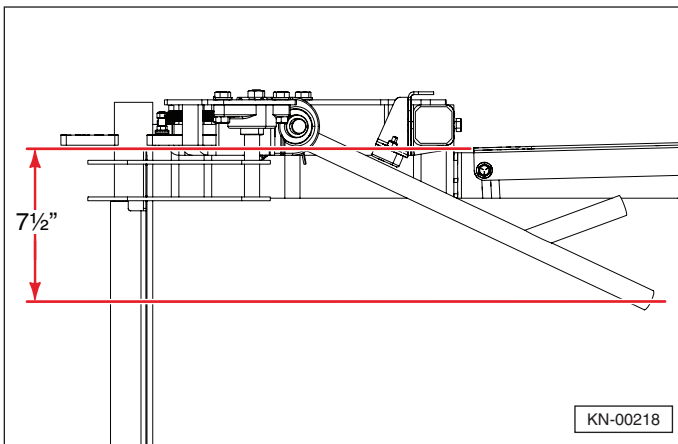





1. The tip of the main tube on the swing arm should be 7-1/2" on center from the end of the outside panel.



9. Transporting

9.1 General Safety

SAFETY INSTRUCTIONS



-  Towing the Hay Accumulator requires care! Both the unit and tow vehicle must be in good working condition. Securely attach the unit to the tow vehicle using a high strength, appropriately-sized hitch pin with a mechanical retainer and attach safety chain.
-  Make sure the safety chain from the unit is securely fastened to the tow vehicle.
-  Check the tires for tread wear, inflation pressure, and overall condition before towing the unit.
-  Inspect the hitch and coupling for wear or damage. **DO NOT** tow the unit using a defective hitch or coupling!
-  Make sure the lug nuts holding the wheels are tight and that none are missing.
-  When towing the unit on the highway, make sure the “Slow Moving Vehicle” placard is clearly visible.
-  Do not allow anyone to stand between the tongue or hitch and the towing vehicle when backing up to the unit.
-  Make sure that the area is clear of children, animals, and other obstacles before moving the unit. This is particularly important with higher noise levels and quiet cabs, as you may not hear people shouting.
-  Do not allow anyone to ride on the unit.

9.2 Safety Chain

WARNING

-  **Unexpected Separation Hazard**
If the safety chain does not have a current certification tag, do not tow the unit until properly certified chains are installed. Substandard safety chains could allow the unit to separate from the tow vehicle, resulting in equipment damage and personal injury.

SAFETY INSTRUCTIONS

- If the unit will be transported on a public highway, a safety chain must be attached to the tow vehicle.
-  Always follow state and local regulations regarding a safety chain when towing farm equipment on a public highway.
-  Be sure to check with local law enforcement agencies for any local regulations or restrictions.
- Do not use any device other than an approved safety chain. Only a safety chain (not an elastic or nylon/plastic tow strap) should be used to retain the connection between the tow vehicle and the unit in the event of separation of the primary attaching system. Install the safety chains by crossing the chains under the tongue and secure to the hitch.

9.3 Highway and Transport Operations

SAFETY INSTRUCTIONS

- Operate the towing vehicle from the operator's seat only.
- Never use independent braking when towing the unit, as loss of control and/or upset of the unit may result.
- Always drive at a safe speed relative to local conditions, and ensure that your speed is low enough for an emergency stop to be safe and secure. Keep speed to a minimum.
- Reduce speed prior to turns to avoid the risk of overturning.
- Avoid sudden uphill turns on steep slopes.
- Always keep the tractor or towing vehicle in gear to provide engine braking when going downhill. Do not coast.
- Use approved accessory lighting, flags, or other necessary warning devices to protect operators of other vehicles on the highway during daylight and nighttime transport. Various safety lights and devices are available from your dealer.

- When driving the tractor and equipment on the road or highway, use flashing amber warning lights and a slow moving vehicle (SMV) identification emblem.
- Some localities prohibit the use of flashing amber lights. Local laws should be checked for all highway lighting and marking requirements.
- Be a safe and courteous driver. Always yield to oncoming traffic in all situations, including narrow bridges, intersections, etc. Plan your route to avoid heavy traffic.
- Be observant of bridge load restrictions. Do not cross bridges rated lower than the gross weight at which you are operating.
- Watch for overhead obstructions and side clearances while transporting.
- Always operate equipment in a position to provide maximum visibility at all times. Make allowances for increased length and weight of the equipment when making turns, stopping, etc.

2. Insert a 1" diameter hitch pin or Grade 8 bolt in the provided hole in the tongue. Install a retainer clip or locking nut, as appropriate.

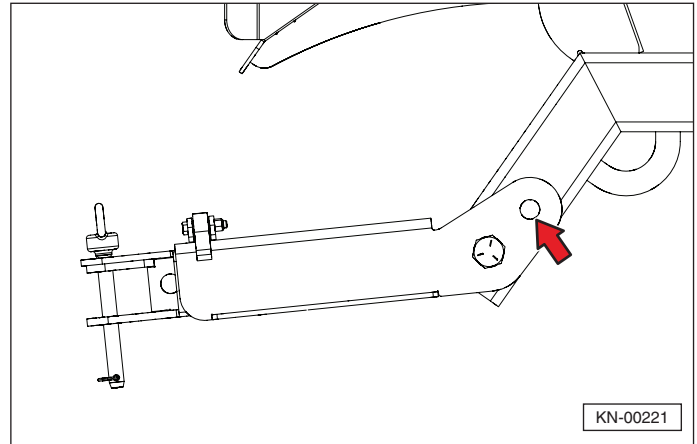

NOTICE

Remove the pin before using the hay accumulator.

9.3.1 Setting the Hitch for Transport

When transporting at high speed, the swivel dolly must be clear of the ground.

1. Using a suitable lifting device, raise the front of the accumulator until the front wheels are off the ground. A jack mount is provided on the left front of the frame for this purpose.

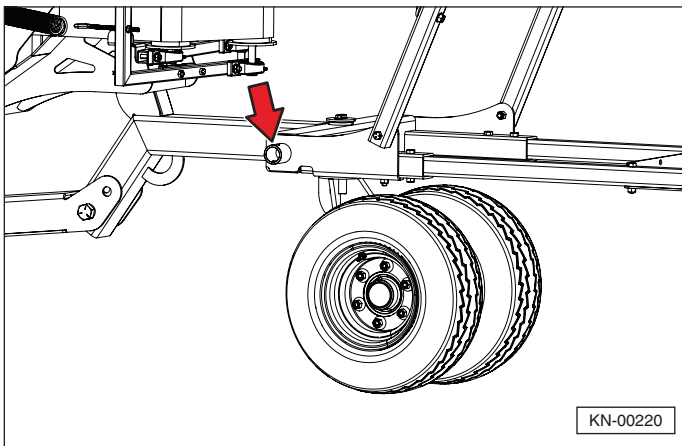

9.3.2 Lights

The hay accumulator is equipped with Agricultural Lights and an Enhanced Flasher Lighting Module to meet ASABE S279 standard. The unit has a 7-pin Agricultural plug. If towing the hay accumulator with a vehicle equipped with a 7-pin Trailer plug, verify proper operation of the lights before towing.

9.4 Pre-towing Checklist

1. Before towing, make sure the maintenance on the tow vehicle and the unit are current. This is very important because towing puts additional stress on the tow vehicle.
2. Check and correct the tire pressures on the tow vehicle and the unit.
3. Make sure the hitch, clevis, and any other equipment that connects the unit and the tow vehicle are properly secured and adjusted. Always inspect the hitch and tongue for cracks or abnormal wear when hooking up.
4. Make sure the hitch is set up for transport. Refer to “9.3.1 Setting the Hitch for Transport” on page 33.

⚠ WARNING



Substandard Parts Hazard

Use only an OEM certified, hardened drawbar pin with a retainer clip. Do not use homemade pins, bolts, or any other type of retaining device. Always install the retainer clip, making sure the hitch and unit are securely fastened to the tow vehicle.

Using a pin not intended for this type of towing can result in unexpected separation of the unit from the tow vehicle, resulting in equipment damage and personal injury.

5. Attach the safety chain from the unit to the tow vehicle. The safety chain should be long enough for tight turns. Don't allow the chain to drag on the pavement because it will wear the chain links, causing an unsafe condition.
6. Prior to towing, have an observer confirm all running lights, brake lights, turn signals, and hazard lights are working on the tow vehicle.
7. Verify the brakes on the tow vehicle are operating correctly.

10. Storage

⚠ WARNING

Not following these safety instructions can result in serious injury and possible death.



Read and understand the Operator's Manual and all safety signs before moving the unit.



Do not permit anyone, especially children, to play on or around the stored unit.

Store the unit in an area away from human activity.

Do not park the equipment where it will be exposed to livestock for long periods of time. Damage and livestock injury could result.

10.1 Placing In Storage

1. Remove all bales and loose hay from the Hay Accumulator.
2. Thoroughly wash the Hay Accumulator with a pressure washer or water hose to remove all dirt, mud, or debris.
3. Select an area that is dry, level, and free of debris (inside a building is ideal). Move the Hay Accumulator to its storage area. Disconnect the Hay Accumulator from the baler following the procedure in "7.5 Detaching From Baler" on page 28.
4. Lubricate all grease points. Make sure all grease cavities have been filled with grease to displace any trapped water from washing.
5. Touch up all paint nicks and scratches to prevent rusting.

10.2 Removing From Storage





1. Grease all lubrication points. Refer to "11.2 Lubrication" on page 37.
2. Attach the accumulator to the baler following the procedure in "7.3 Attaching to Baler" on page 27.
3. Before placing the accumulator back into service, replace any worn or defective parts and perform the Pre-Operation Checklist.

11. Maintenance



11.1 Maintenance Safety



WARNING

Failure to comply with the following safety instructions could result in serious injury and possibly even death.

 **Personal Protection Equipment**
Wear close fitting and belted clothing to avoid getting caught in moving parts. Wear personal protection equipment (PPE), which may include safety glasses, safety shoes, gloves, etc., appropriate for the work site and working conditions.

 **Damaged Parts Hazard**
Do not use the Hay Accumulator if any parts are damaged. If the Hay Accumulator is believed to have a defect which could cause it to work improperly, immediately stop using it and remedy the problem before continuing.

 **No Unauthorized Modifications**
Do not modify the Hay Accumulator or safety devices. Do not weld on the unit. Unauthorized modifications may impair the unit's function, or create safety hazards, and will void the warranty. If the Hay Accumulator has been altered in any way from the original design, the manufacturer does not accept any liability for injury or warranty.



 **Crush Hazard**
Always set the Hay Accumulator on safety stands or on the ground and chock the wheels when performing maintenance.



 **Good Working Condition**
Keep all parts in good condition and properly installed. Fix damage immediately. Replace worn or broken parts.



 **Replacement Parts**
If replacement parts are necessary, genuine factory replacement parts must be used to restore the unit to its original specifications. Unapproved parts could create a safety hazard. The manufacturer will not accept responsibility for damages as a result of the use of unapproved parts.



SAFETY INSTRUCTIONS

The following safety instructions are provided to help prevent injury or limit equipment damage.

 **Safety Equipment**
A fire extinguisher and first aid kit should be readily accessible while performing maintenance on this equipment.

 **Clean Work Area**
Do not leave tools lying around the work area. Follow good shop practices. Keep service area clean and dry. Be sure electrical outlets and tools are properly grounded. Use adequate light.

 **Use the Right Tools**
Use the correct tools, jacks, hoists, or other tools that have the capacity for the job.

 **Proper Support**
Use certified safety stands rated to support the load when working beneath the equipment, or performing repairs, service, or maintenance.

The Hay Accumulator weighs 2300 lbs. Before working underneath, place it on a minimum of four jack stands, with a load rating of at least 2000 lbs. each.

Do not position the jack stands under wheels, axles, or wheel supports, as they may rotate and cause the unit to fall.

Make sure the jack stands are stable and the unit is approximately level. Test the stability of the load before working underneath.

If the Hay Accumulator is attached to the tractor and baler, set the brakes, disengage the PTO and all power drives, shut off the engine, remove the ignition key, chock the tractor wheels, and block the Hay Accumulator before working underneath.

Preventive maintenance is one of the most cost-effective practices that any equipment owner can implement. Taking a few minutes of your time to inspect the Hay Accumulator can save hundreds and even thousands of dollars. These savings can come from:

- Increased operating time (no unscheduled breakdowns in the field).
- Normal wear items will last longer because they have been properly maintained and lubricated.
- Less chance of someone becoming injured due to parts that may fail because of mistreatment or abuse.

Preventive maintenance should only be completed by qualified persons. In no way are these instructions intended to encourage service of the Hay Accumulator by anyone who is not qualified to do so. The overall performance of the Hay Accumulator is directly related to the skill and knowledge of the person performing the service. If the mechanic cannot see potential problems, or is unaware of the signs of potential problems, the service may be a costly waste of time.

Before working on the Hay Accumulator, stop the towing vehicle, set the brakes, disengage the PTO, shut off the engine, and remove the ignition key. Never replace hex bolts with less than Grade 5 bolts. After servicing, be sure all tools, parts, and service equipment are removed. Where replacement parts are necessary for periodic maintenance and servicing, genuine factory replacement parts must be used to restore your equipment to original specifications. The manufacturer will not claim responsibility for damages as a result of the use of unapproved parts and/or accessories.

If equipment has been altered in any way from the original design, the manufacturer does not accept any liability for injury or warranty.

11.2 Lubrication

1. Grease the fittings on the belt tensioner bearings annually with an SAE multipurpose lithium base grease.

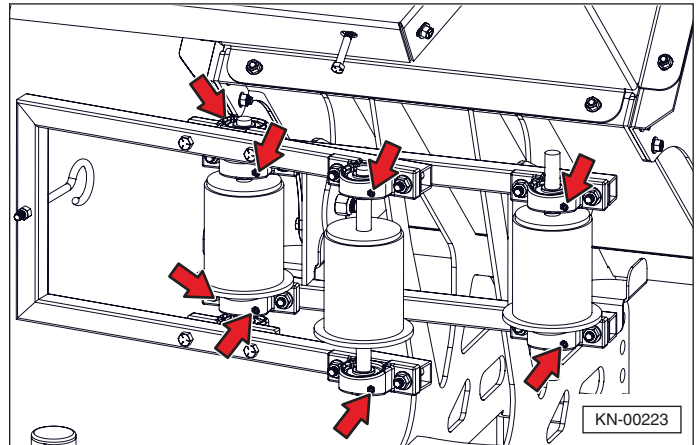

2. Grease the fittings on the end gate bearings and swing arm bearings annually with an SAE multipurpose lithium base grease.

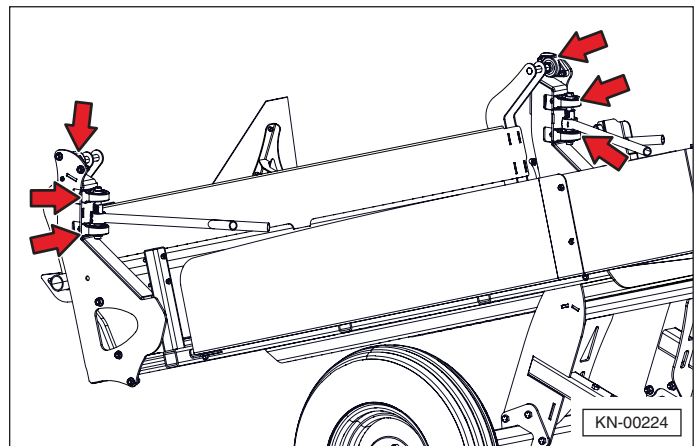

3. Grease the fittings on the trip flipper arm bearings annually with an SAE multipurpose lithium base grease.

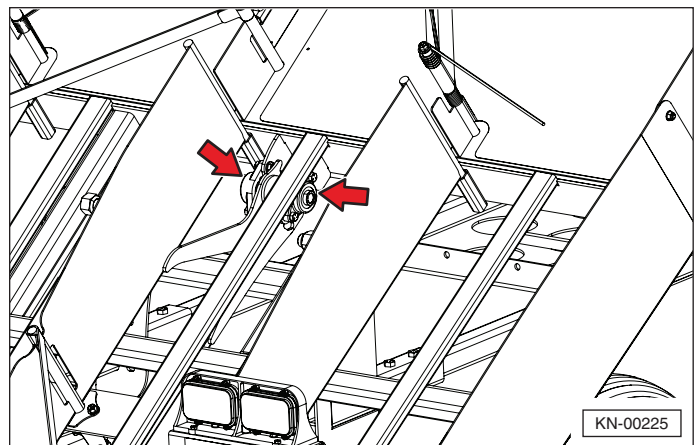

- Grease the fittings on the back shaft bearings annually with an SAE multipurpose lithium base grease.

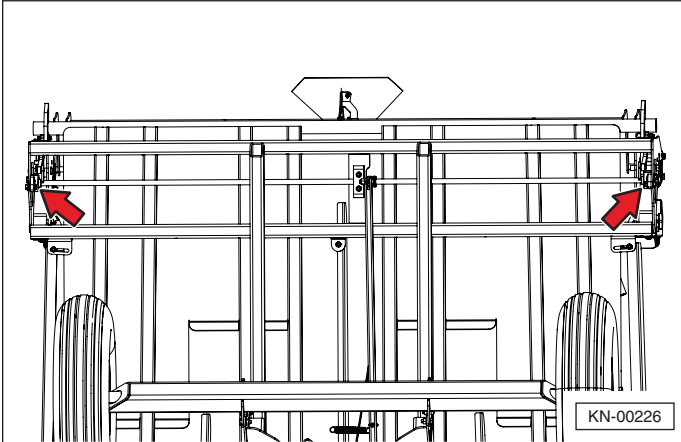

- Grease the fittings on the wheel bearings weekly when in service with an SAE multipurpose lithium base grease.

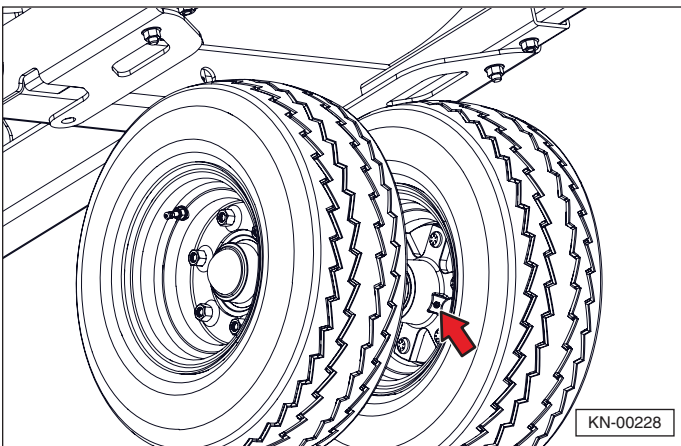
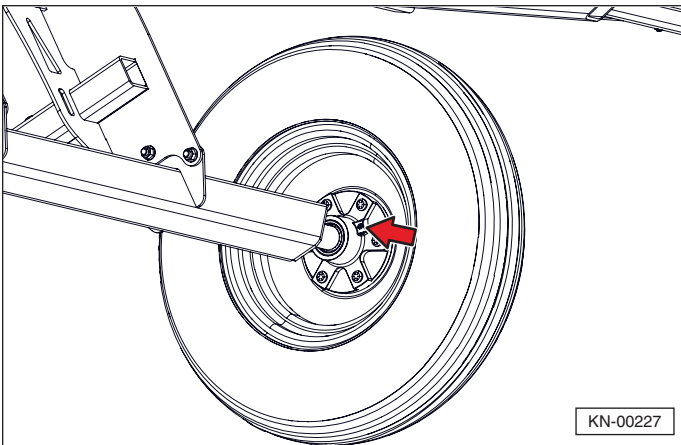

- Grease the fitting on the swivel dolly annually with an SAE multipurpose lithium base grease.

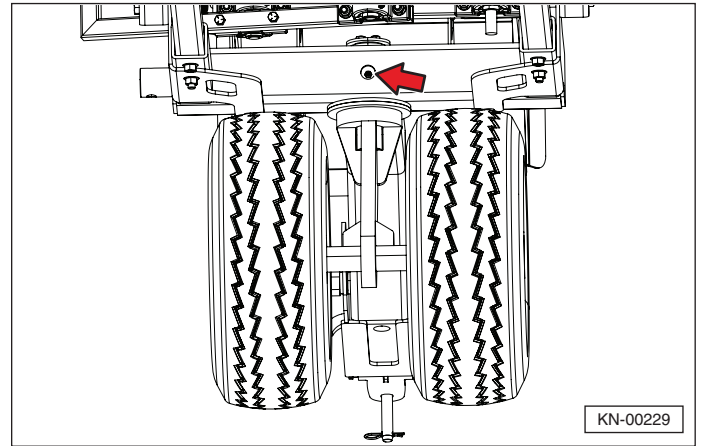

- Grease the fitting on the tongue pivot annually with an SAE multipurpose lithium base grease.

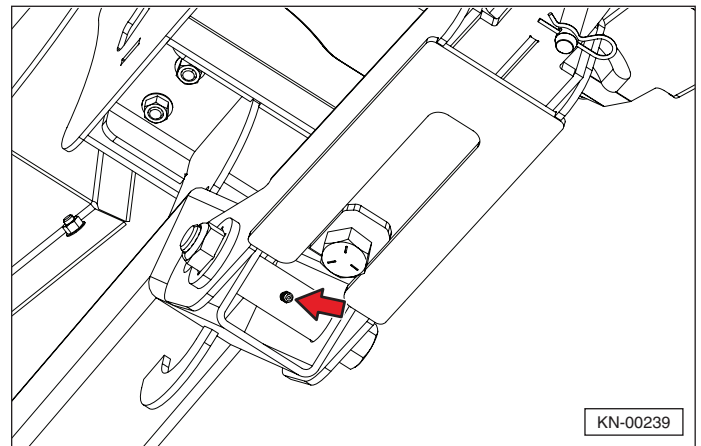

11.3 Wheel Bearing Adjustment

Check the wheel bearings for excessive end play annually. To adjust the wheel bearings:

- Remove the dust cap and cotter pin.
- Lift the tire and slowly rotate it while tightening the spindle nut.
- Tighten the spindle nut until a slight drag is felt on the rotating wheel.
- Re-install the dust cap and cotter pin.

11.4 Swivel Dolly Bushings

Check the swivel dolly for excessive play annually. If necessary, replace the non-metallic bushings.

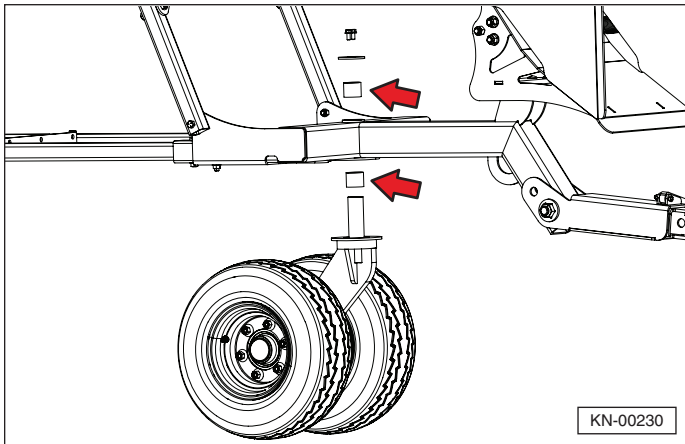

11.5 Tire Safety



Inflating or servicing tires can be dangerous. Whenever possible, trained personnel should be called to service and/or mount tires.

11.6 Tire Inflation

Check the tire pressure before each use. The recommended tire inflation pressure is 34 psi (235 kPa).

11.7 Bolt Torque Requirements



It is extremely important to apply and maintain proper torque on all bolts. Use a torque wrench to assure the proper amount of torque is being applied to the fastener.

Start all bolts or nuts by hand to prevent cross threading.

Torque figures indicated in the chart are used for non-greased or non-oiled threads unless otherwise specified. Therefore, do not grease or oil bolts or cap screws unless otherwise specified in this manual. When using locking elements, increase torque values by 5%.

The chart gives correct torque values for various bolts and cap screws. Tighten all bolts to the torque specified in the chart, unless otherwise noted. Check the tightness of the bolts periodically, using the bolt torque chart as a guide. Always replace hardware with the same Grade bolt.

11.8 Standard Torque Values

Bolt Diameter	English Bolt Torque Specifications			
	Grade 5  3 Radial Lines		Grade 8  6 Radial Lines	
	ft.lbs.	N·m	ft.lbs.	N·m
1/4"	9	12	12	17
5/16"	19	25	27	36
3/8"	33	45	45	63
7/16"	53	72	75	100
1/2"	80	110	115	155
9/16"	115	155	165	220
5/8"	158	215	220	305
3/4"	290	390	398	540
7/8"	420	570	650	880
1"	630	850	970	1320

WARNING



Equipment Failure

The proper torque value for bolts and cap screws is identified by their head markings. Replacing higher "Grade" bolts (Grade 5) with lower Grade bolts will lead to equipment failure and can result in injury or death. Always use replacement bolts with the same Grade markings as the removed bolt.

11.9 Welding Repairs



Before performing any type of welding repair to the Hay Accumulator, contact Norden Mfg. for approval. Repair welding must be done with care and with procedures that may be beyond the capabilities of the ordinary welder.

WARNING

Personal Injury Hazard

Repairs or modifications to the Hay Accumulator can result in serious injury or death should these repairs fail.

NOTICE

Anyone performing a welding repair should be certified in accordance to the American Welding Society (AWS) standards.

11.10 Service Record

The period recommended is based on normal operating conditions. Severe or unusual conditions may require more frequent service.

Copy this page to continue record.

Hours and Serviced By																			
Maintenance																			
Daily																			
Make sure the tires are inflated properly and the lug nuts are tight.																			
Make sure all retainer clips and pins are in place.																			
Inspect the belted base chute and gates for wear and damage.																			
Weekly																			
Make sure all fasteners are tightened to proper torque. Refer to "11.8 Standard Torque Values" on page 39.																			
Grease the wheel bearings. Refer to "11.2 Lubrication" on page 37.																			
Annually																			
Grease the belt tensioner bearings, end gate bearings, back shaft bearings, tongue pivot, swing arm bearings, and swivel dolly bushings. Refer to "11.2 Lubrication" on page 37.																			
Inspect the wheel bearings for excessive end play. Refer to "11.3 Wheel Bearing Adjustment" on page 38.																			
Make sure all fasteners are tightened to proper torque. Refer to "11.8 Standard Torque Values" on page 39.																			
Check accumulator bed, gates, and linkage for damage.																			
Inspect the belted base chute and tensioner for wear and damage.																			
Make sure the hitch, hitch bolts, and hitch pin are in good condition. Do not use homemade or shop made pins.																			
Wash the accumulator.																			

12. Parts Section

12.1 Ordering Parts

We manufacture a quality product that requires very little maintenance or repair. However, should a part break or become damaged, our knowledgeable staff can make sure you receive the part(s) to put your unit back into operation.

12.2 Contact Information

For replacement decals, questions, or to order parts, contact:

Norden Mfg
4210 Kinsman Road NW
North Bloomfield, OH 44450

Phone: 877-296-5851

Fax: 440-693-4336

E-mail: parts@Nordenmfg.com

12.3 Decals



To prevent serious injury or death from not following posted safety instructions, make sure all decals are attached to the unit and are legible at all times.

Safety decals provide a vital role in helping to reduce injuries and/or possibly even death. To ensure the greatest level of safety, all decals must be in place and legible at all times. Remember, it is the users responsibility to maintain these decals.

All decals must be in place and legible or all warranties are void.

12.4 Hay Accumulator Undercarriage

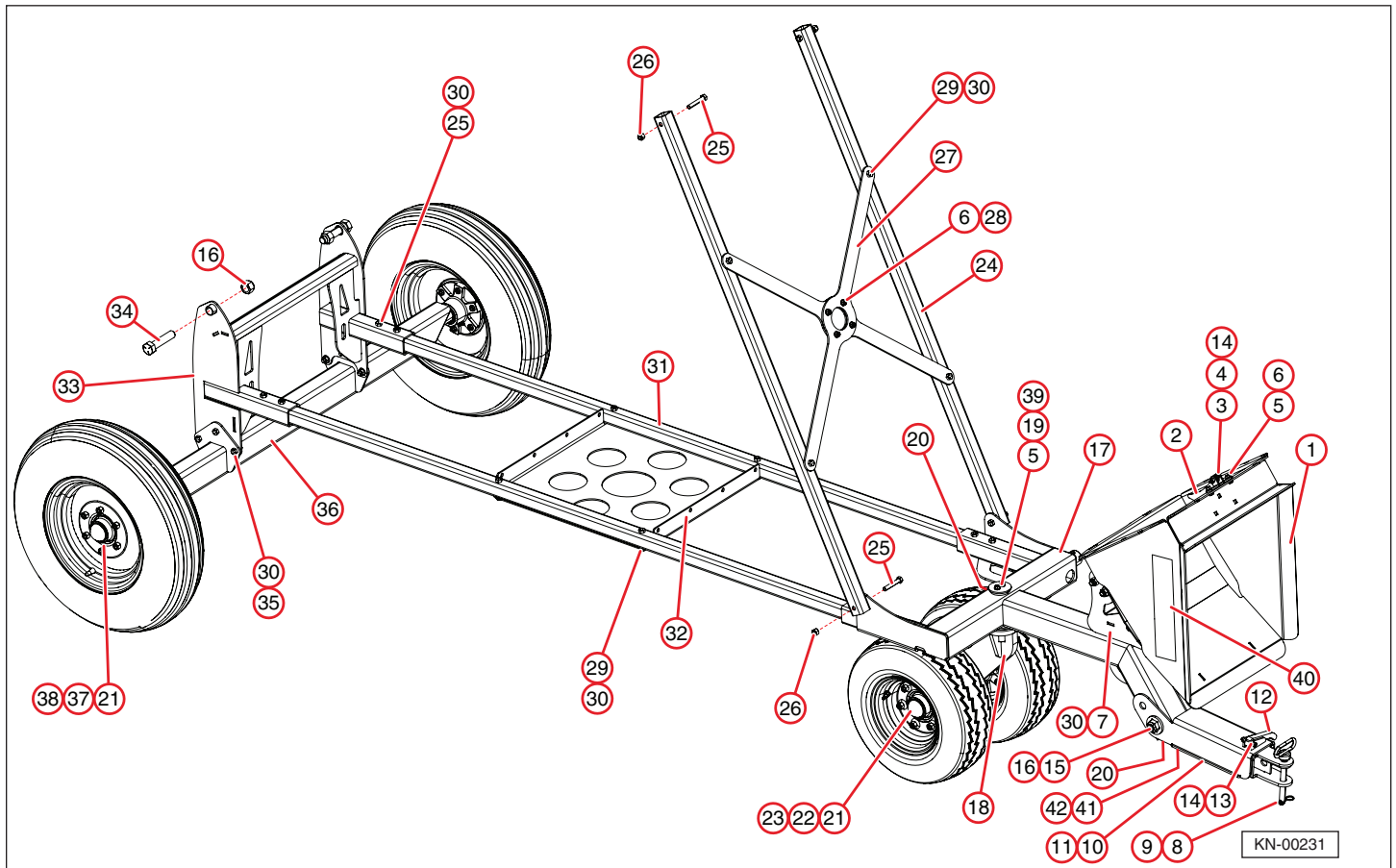

Item	Part Number	Description	Qty.
1	1000760	Weldment, Base Chute	1
2	1001911	Chute Dog	1
3	1001900	Bracket, Chute Dog	1
4	1006360	Bolt, Hex, 3/8 x 1-3/4" Grade 5	1
5	1006330	Bolt, Serrated Flange, 3/8 x 3/4" Grade 5	4
6	1006190	Nut, Serrated Flange, 3/8-16	6
7	1007520	Bolt, Carriage, 1/2 x 1" Grade 5	4
8	1007560	Pin, Hitch, 3/4" x 6"	1
9	1006910	Pin, Cotter, 1/8 x 2-1/2"	1
10	1000470	Tongue	1
11	1000460	Tongue Insert	1
12	1000480	Tongue Lock	1
13	1007550	Bolt, Hex, 3/8 x 2" Grade 5	1
14	1006090	Nut, Lock, Nylon, 3/8-16	2
15	1007450	Bolt, Hex, 1 x 6-1/2" Grade 5	1
16	1007500	Nut, Lock, Nylon, 1-8	3
17	1000920	Frame, Front	1
18	1000900	Weldment, Front Axle	1
19	1005230	Swivel Cap, Dual Dolly	1
20	1003730	Fitting, Grease (Not Shown)	2
21	1005200	Hub Assembly*	2
22	1003600	Wheel, Front	2
23	1003570	Tire, 20.5 x 8 - 10	2

Item	Part Number	Description	Qty.
24	1001420	Pole, Upright	2
25	1006250	Bolt, Hex, 1/2 x 3" Grade 5	12
26	1006110	Nut, Lock, Nylon, 1/2-13	4
27	1000910	Cross, Front	2
28	1006340	Bolt, Serrated Flange, 3/8 x 1" Grade 5	4
29	1007580	Bolt, Hex, 1/2 x 2-3/4" Grade 5	8
30	1006210	Nut, Serrated Flange, 1/2-13	26
31	1001210	Pole, Reach	2
32	1001190	Connector, Reach Pole	1
33	1001270	Connector, Rear Axle	1
34	1007510	Bolt, Hex, 1 x 4-1/2" Grade 5	2
35	1006230	Bolt, Hex, 1/2 x 1-1/4" Grade 5	6
36	1001280	Axle, Rear	1
37	1003610	Wheel, Rear	2
38	1003580	Tire, Rear, 9.5L-15SL	2
	1001000	Combination of 37&38 (Tire and wheel)	
39	1007720	Bushing, Nonmetallic	2
40	1007980	Tape, Reflective, 2" H x 9", Amber	2
41	1000450	Stop, Tongue Insert	1
42	1007710	Bolt, Hex, 1 x 1-1/2" Grade 5	1

* Refer to separate page for parts.

12.5 Hub Assembly

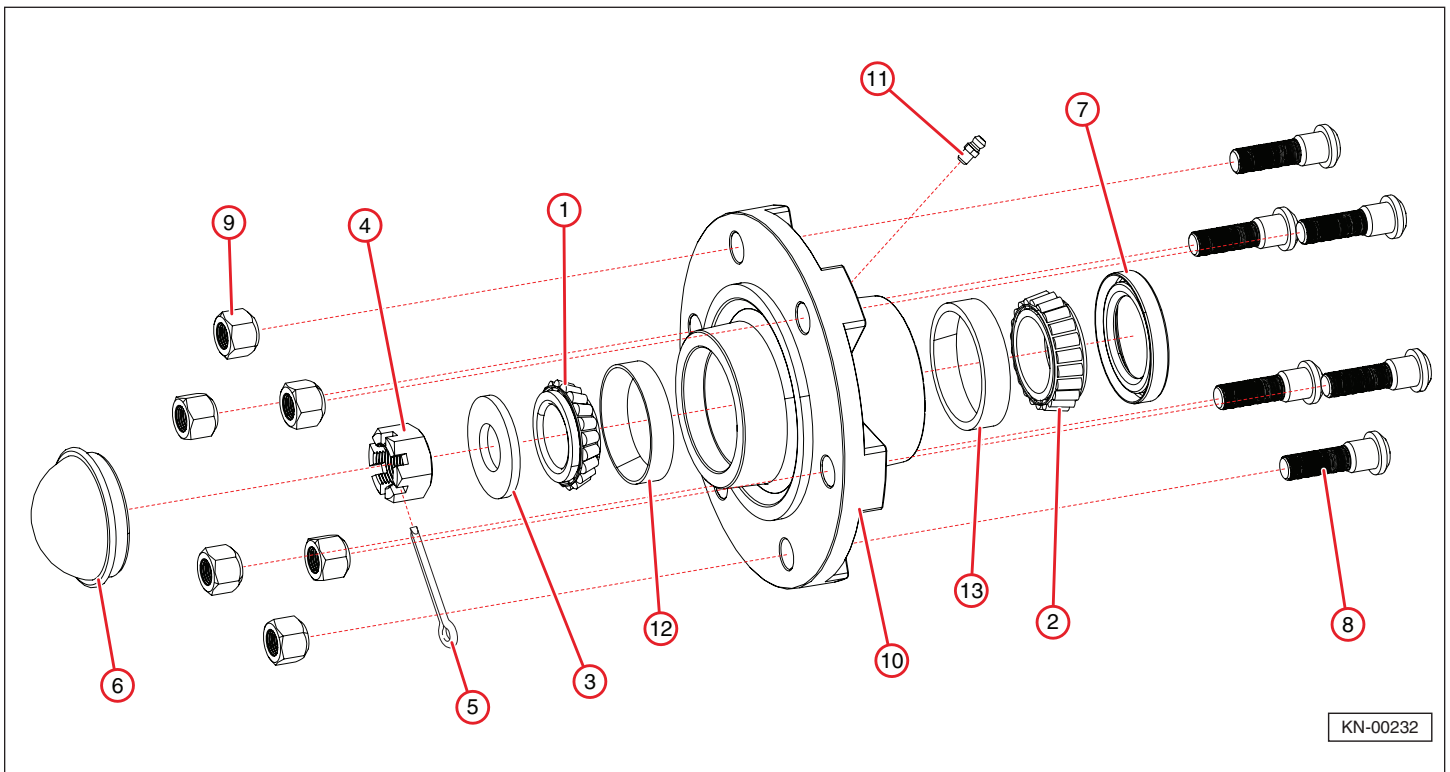

KN-00232

Item	Part Number	Description	Qty.
1	1003640	Bearing, Outer	1
2	1003630	Bearing, Inner	1
3	1003660	Washer	1
4	1003700	Nut, Hex, Slotted, 7/8-14	1
5	1003720	Pin, Cotter, 1/8 x 1-1/2"	1
6	1003690	Dust Cap	1
7	1003710	Seal, Grease	1
8	1003670	Stud, Wheel	6
9	1003680	Nut, Lug	6
10	1003650	Hub	1
11	1003730	Fitting, Grease	1
12	1005220	Race, Bearing, Outer	1
13	1005210	Race, Bearing, Inner	1
—	1009450	Service Kit, Includes items 1, 2, 3, 4, 5, 6, 7, 12, 13	—

12.6 Accumulator Bed and Chute

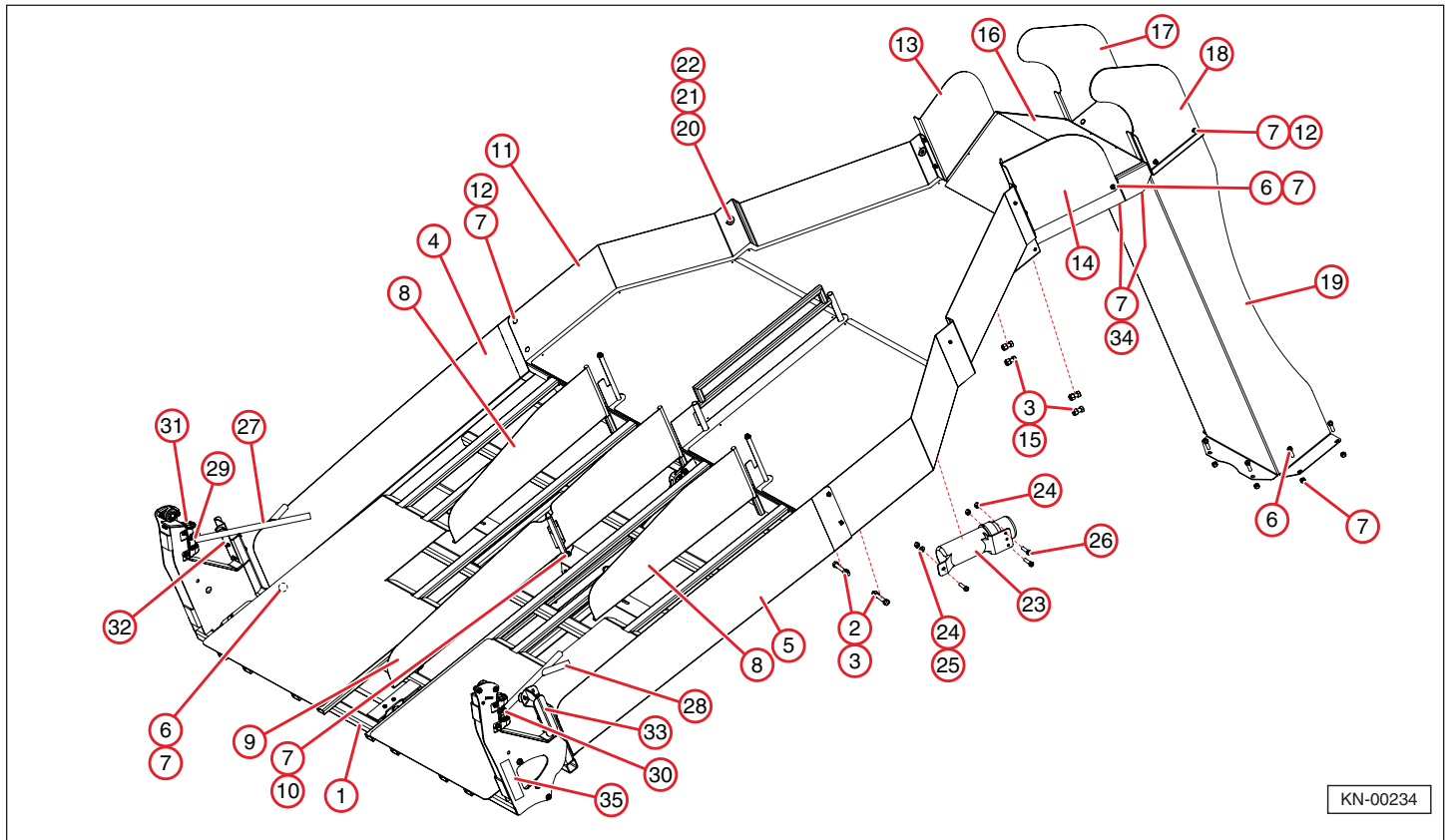

Item	Part Number	Description	Qty.
1	1000712	Bed, Accumulator, Rear	1
2	1006250	Bolt, Hex, 1/2 x 3" Grade 5	2
3	1006210	Nut, Serrated Flange, 1/2-13	6
4	1001110	Panel, Outside, Left	1
5	1001120	Panel, Outside, Right	1
6	1006330	Bolt, Serrated Flange, 3/8 x 3/4" Grade 5	25
7	1006190	Nut, Serrated Flange, 3/8-16	30
8	1000840	Divider	2
9	1000870	Divider, with Switch	1
10	1006340	Bolt, Serrated Flange, 3/8 x 1" Grade 5	3
11	1001051	Platform, Gate	1
12	1006300	Bolt, Carriage, 3/8 x 3/4"	8
13	1000810	Side, Chute Platform, Left	1
14	1000820	Side, Chute Platform, Right	1
15	1006230	Bolt, Hex, 1/2 x 1-1/4" Grade 5	4
16	1000830	Platform, Chute	1
17	1000770	Extension, Chute, Left	1
18	1000780	Extension, Chute, Right	1

Item	Part Number	Description	Qty.
19	1001330	Chute, Straight	1
20	1003560	Bumper, Butyl Rubber	6
21	1006420	Bolt, Hex, 1/4 x 3/4" Grade 5	6
22	1006070	Nut, Lock, Nylon, 1/4-20	6
23	1006430	Document Canister	1
24	1006080	Nut, Lock, Nylon, 5/16-18	3
25	1006140	Washer, Flat, 5/16" SAE	1
26	1006290	Bolt, Hex, 5/16 x 1" Grade 5	3
27	1000491	Swing Arm, Left	1
28	1007011	Swing Arm, Right	1
29	1007920	Rear Turn Spring, Left	1
30	1007930	Rear Turn Spring, Right	1
31	1004170	Bearing, Swing Arm	4
32	1000500	Bracket, Bumper, Left	1
33	1000510	Bracket, Bumper, Right	1
34	1006310	Bolt, Carriage, 3/8 x 1"	2
35	1007980	Tape, Reflective, 2" H x 9", Amber	2

12.7 Linkage System

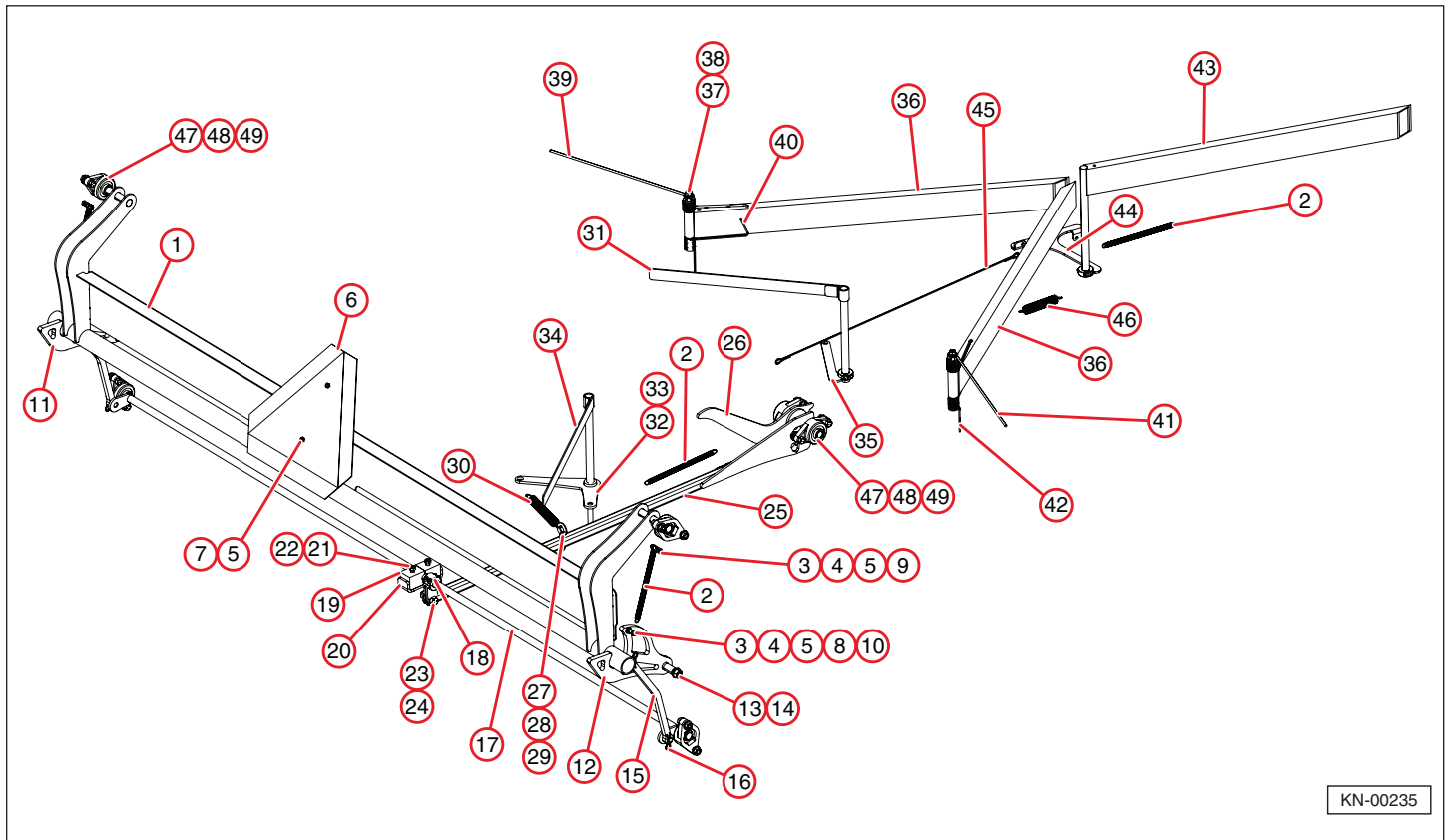

KN-00235

Item	Part Number	Description	Qty.
1	1000671	Back Gate	1
2	1005180	Spring, Return, 8-1/2"	4
3	1007600	Bushing, 3/8 OD x 5/16 ID, Brass	4
4	1007660	Nut, Hex, 1/4-20 Grade 5	4
5	1006070	Nut, Lock, Nylon, 1/4-20	6
6	1003750	SMV Sign	1
7	1006420	Bolt, Hex, 1/4 x 3/4" Grade 5	2
8	1007640	Bolt, Hex, 1/4 x 1-3/4" Grade 5	2
9	1007630	Bolt, Hex, 1/4 x 1-1/4" Grade 5	2
10	1006140	Washer, Flat, 5/16"	4
11	1000520	Hook, Back Gate, Left	1
12	1000530	Hook, Back Gate, Right	1
13	1007380	Bolt, Carriage, 1/2 x 3-1/4"	2
14	1006210	Nut, Serrated Flange, 1/2-13	2
15	1000601	Link, Trip, Back Gate	2
16	1008280	Pin, Cotter, 1/8 x 1-7/8"	4
17	1000561	Backshaft	1
18	1007160	Ear, Backshaft	1
19	1000550	Brace, Backshaft, Half	2
20	1000541	Clip, Backshaft Brace	1
21	1006860	Bolt, Hex, 3/8 x 2-1/2" Grade 5	2
22	1006190	Nut, Serrated Flange, 3/8-16	2
23	1007650	Bolt, Hex, 1/2 x 1-3/4" Grade 5	1
24	1006110	Nut, Lock, Nylon, 1/2-13	1
25	1000621	Reach, Back Gate Trip	1

Item	Part Number	Description	Qty.
26	1001361	Trip Flipper, Back Gate	1
27	1007080	Eyebolt, 5/16 x 1-3/4"	1
28	1006600	Nut, Hex, 5/16-18 Grade 5	1
29	1006080	Nut, Lock, Nylon, 5/16-18	1
30	1007730	Spring, Extension, 6"	1
31	1001032	Gate Switch, Left, Short	1
32	1000661	Trip Slider, Back Gate	1
33	1007610	Bolt, Hex, 5/16 x 1/2" Grade 5	1
34	1001041	Trip Switch	1
35	1007101	Arm, Switch	1
36	1000990	Gate, Outside, Flat	2
37	1006330	Bolt, Serrated Flange, 3/8 x 3/4" Grade 5	2
38	1006160	Washer, Flat, 7/16"	2
39	1010250	Spring, Gate Actuating, Left	1
40	1005670	Spring, Gate Return, Left	1
41	1010260	Spring, Gate Actuating, Right	1
42	1005680	Spring, Gate Return, Right	1
43	1000950	Gate, Center	1
44	1007091	Arm, Gate	1
45	1007800	Cable Assembly, Center Gate	1
46	1005170	Spring, Center Gate, 12"	1
47	1003110	Bearing, Flange, 3/4"	6
48	1007270	Bolt, Hex, 7/16 x 1-1/4" Grade 5	12
49	1006200	Nut, Serrated Flange, 7/16-14	12

12.8 Belt and Tensioner

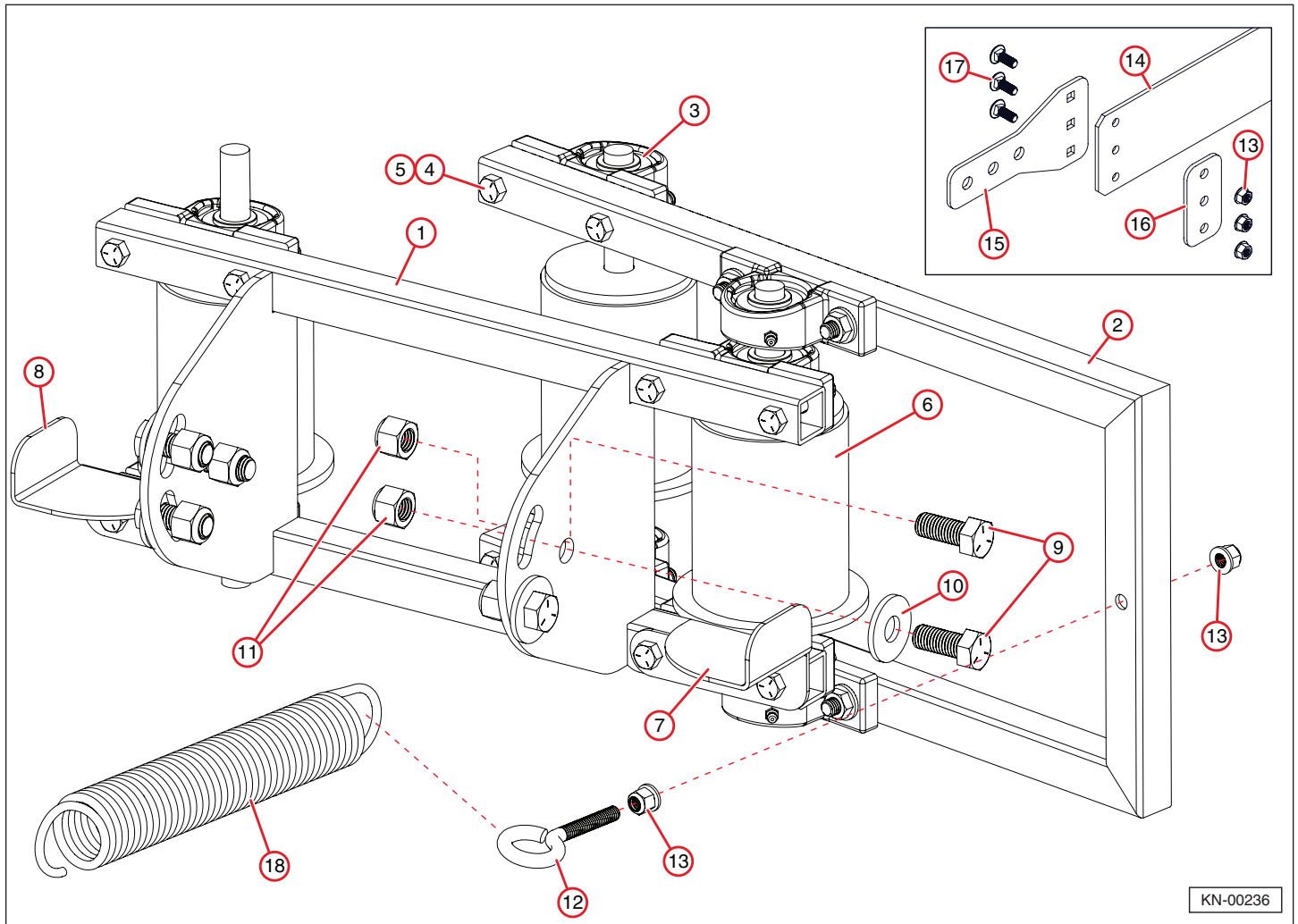

Item	Part Number	Description	Qty.
1	1003360	Frame, Roller	1
2	1003370	Frame, Tensioner	1
3	1003410	Bearing	8
4	1006380	Bolt, Hex, 7/16 x 2-1/2", Grade 5	16
5	1006200	Nut, Serrated Flange, 7/16-14	16
6	1003380	Roller, Belt	3
7	1003390	Saddle, Belt, Left	1
8	1003400	Saddle, Belt, Right	1
9	1006400	Bolt, Hex, 5/8 x 1-1/2", Grade 5	6

Item	Part Number	Description	Qty.
10	1006180	Washer, Flat, 5/8"	4
11	1006120	Nut, Lock, Nylon, 5/8-11	6
12	1006440	Eyebolt, 3/8"	1
13	1006190	Nut, Serrated Flange, 3/8-16, Grade 5	8
14	1006750	Belt	1
15	1006760	Belt End Plate, Large	2
16	1006770	Belt End Plate, Small	2
17	1006310	Bolt, Carriage, 3/8 x 1", Grade 5	6
18	1006590	Spring, Belt Tensioner	1

12.9 Bale Chamber Extension

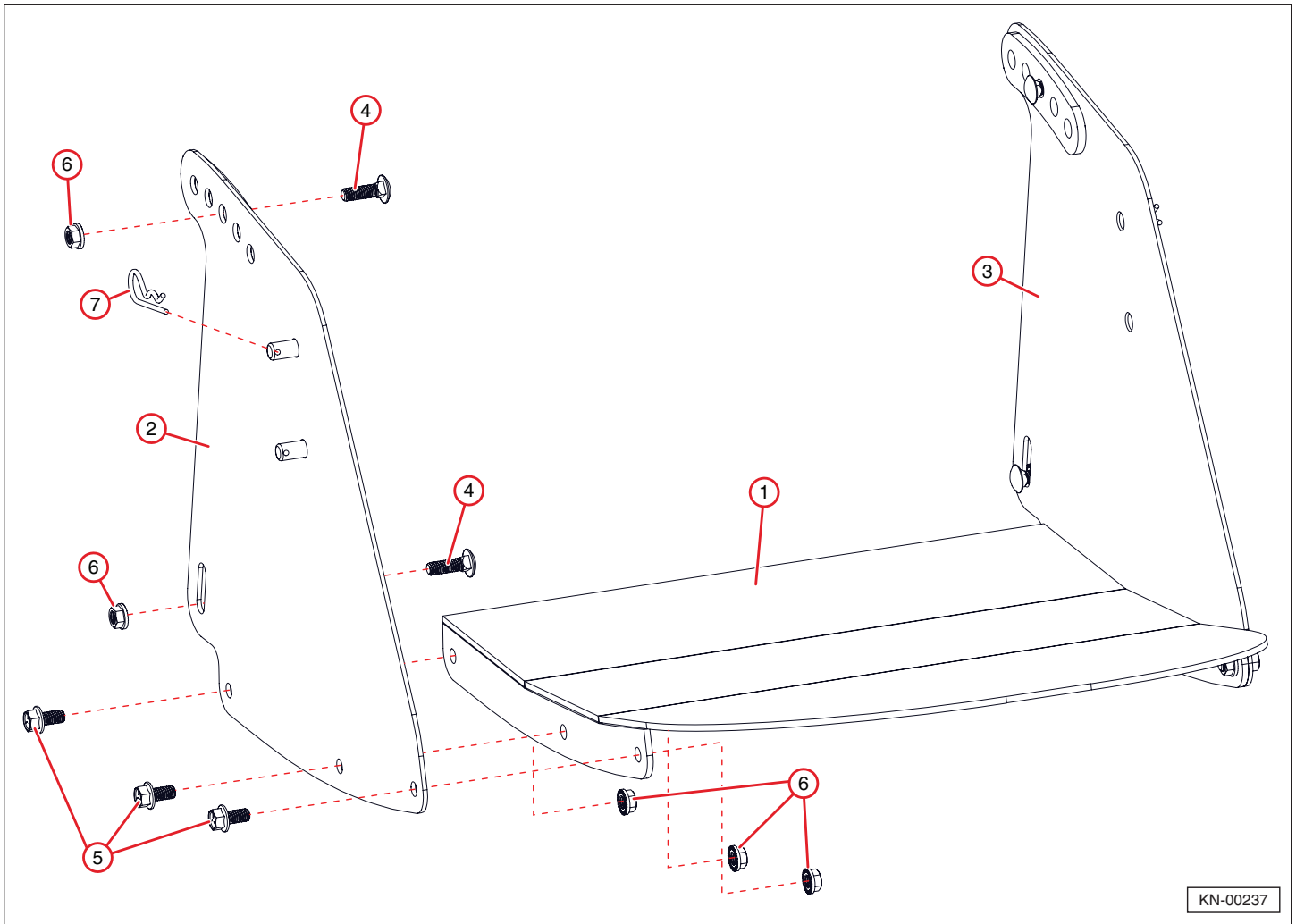

Item	Part Number	Description	Qty.
1	1004420	Bottom, Chamber Extension	1
2	1004430	Side, Chamber Extension, Left	1
3	1004440	Side, Chamber Extension, Right	1
4	1006320	Bolt, Carriage, 3/8 x 1-1/4", Grade 5	4
5	1006330	Bolt, Serrated Flange, 3/8 x 3/4", Grade 5	6
6	1006190	Nut, Serrated Flange, 3/8-16, Grade 5	10
7	1006910	Pin, Cotter, Reuseable	2

12.10 Lighting

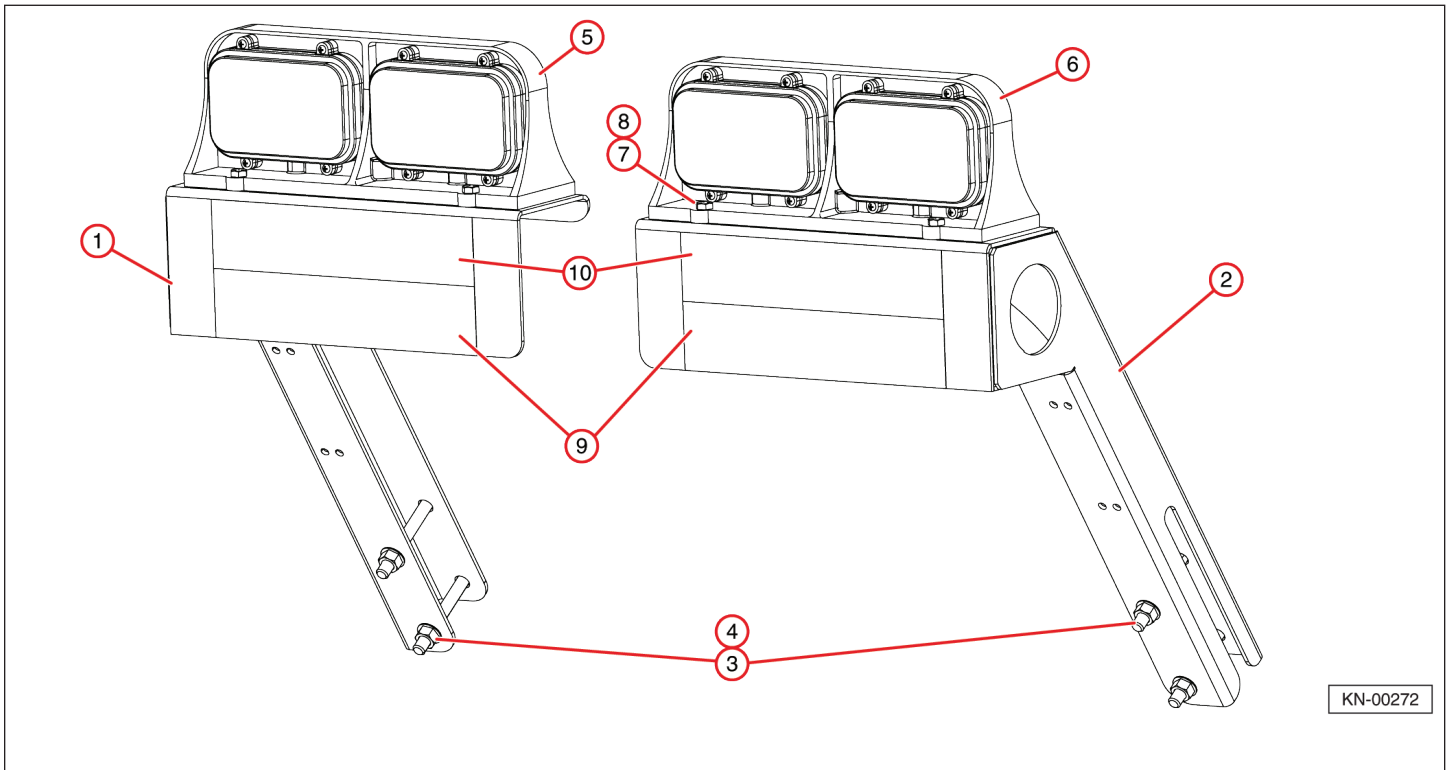

Item	Part Number	Description	Qty.
1	1001301	Bracket, Light, Left	1
2	1001311	Bracket, Light, Right	1
3	1006390	Bolt, Hex, 7/16 x 3", Grade 5	4
4	1006200	Nut, Serrated Flange, 7/16-14, Grade 5	4
5	1004180	Light, Rear, Left	1
6	1004190	Light, Rear, Right	1
7	1007620	Bolt, Hex, 1/4 x 1", Grade 5	8
8	1006070	Nut, Lock, Nylon, 1/4-20, Grade 5	8
9	1007990	Tape, Reflective, 2" H x 9", Red	2

Item	Part Number	Description	Qty.
10	1008000	Tape, Reflective, 2" H x 9", Orange	2
11	1007880	Harness, Rear, Left, 5' (Not Shown)	1
12	1007910	Harness, Rear, Right, 8' (Not Shown)	1
13	1007070	Module, Enhanced Lighting (Not Shown)	1
14	1008010	Harness, Main, 21' (Not Shown)	1
15	1008020	Harness, Baler Extension, 23' (Not Shown)	1

NOTES

NOTES



Norden Mfg LLC
4210 Kinsman Road NW
North Bloomfield, OH 44450

(877) 296-5851
www.nordenmfg.com
support@nordenmfg.com

Kuhns Mfg is the successor to Norden Mfg  and all liability and warrenty claims are transferable.

1008340 Rev. E
Revised 11-05-2021